



GRAND RIBS AND INFLATABLE BOATS



2014
THE SPIRIT OF DISCOVERY



ADVANCED PERFECTION

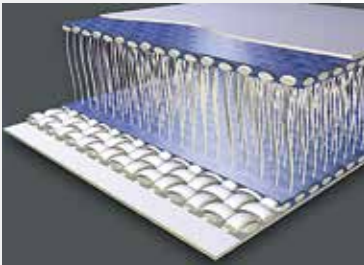

Double-wall drop stitch materials for high-pressure inflatable floors

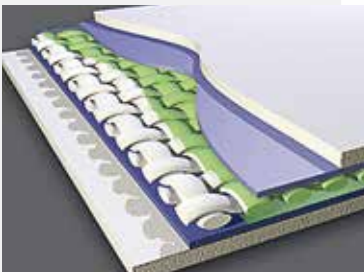

5-layers plastomer coated reinforced fabric for the inflatable tubes

★ INNOVATIONS, INNOVATIONS, INNOVATIONS

The key ingredient of GRAND's success is our innovations. By utilizing state-of-the-art engineering with extensive research and development, we not only raise the bar of quality, we provide the finest contemporary naval architecture available! Combined with our extensive experience in the aerospace industry, the aerodynamic and aircraft technology used in our advanced design and production processes results in a model that's tough to beat. With GRAND, your enjoyment will always be backed by our revolutionary technology.

★ MAINTAINING THE HIGHEST STANDARDS

The fact that our internal quality control exceeds the standards of our competitors, all GRAND models meet the requirements of the International Standard ISO/FDIS-6185, European Community EEC Directive for Recreational Crafts 94/25/EC, and a number of other strict international and national quality standards. This alone clearly indicates that safety and reliability is the driving force behind GRAND. But it's you, our customer, and your invaluable feedback that has earned GRAND a reputation of being the Number One choice among recreational boaters.

★ BUILT IN EUROPE

We are proud to mention that each GRAND is a pure EUROPEAN-BUILT product, with no compromise on quality of workmanship, materials and engineering. We believe in expertise of our European skilled manufacturing professionals and a unique GRAND quality control system, that stands up to the toughest boatbuilding traditions worldwide. Delivering to you a Real Quality, we prove the genuine origin of each part of your GRAND boat, and we would have it no other way!

★ WHERE QUALITY COUNTS

We have a law at GRAND — use the Best materials from the Best suppliers. We feel it's the only way to ensure the greatest quality. All parts and systems are built from reliable and credible brands. For instance, GRAND's inflatables are made of five layers coated 1100 Dtex and 1680 Dtex reinforced MIRASOL and VALMEX fabrics to ensure outstanding durability and abrasion resistance for life! If the best product isn't available, we create our own. Our original new HTL adhesive not only offers structural integrity, it also withstands temperatures up to 90 Degree C!

To ensure you receive the best product for the value, our buoyancy tubes are made of extra-strength CSM (ORCA/TREVIRA) for our high-end boats. With GRAND, there are advantages on and off the water!



★ DRIVEN TO PERFECTION

Every GRAND model incorporates a unique combination of innovative techniques, patented designs and our years of expertise. Utilizing the latest CAD/CAM technology with the most advanced software, every GRAND is perfected to the smallest detail to ensure the utmost quality. Once a model has been built, we perfect it even more with an extensive on-water sea trial in the harshest conditions before it even sees a showroom floor!

NEW OPEN CELL FOAM

Starting from Season 2014 GRAND starts using a new and more advanced type of the foam for all GRAND boats upholstery: water transparent OPEN CELL FOAM. This new type of the foam does not suck and hold the water at all — water just flows through the foam and immediately drains out. This nice feature keeps all the cushions more dry and gives more comfortable feeling!



FIBERGLASS STEP ENDS OF INFLATABLE TUBES

Most of our RIBs either come as standard, or might be equipped with unique feature, developed by GRAND — fiberglass step ends of inflatable tube:

- it is awesome when you are swimming, boarding or docking,
- it is safe and comfortable to stand or even seat on it,
- it perfectly works as a passive trim-tab, pushing the bow down.

NEW "DART" HULL SYSTEM FOR RIBS

New "DART" system for rigid hulls is the next unique and original idea from GRAND, created to improve utility characteristics and performance with:



- More flotation and stability at the back
- Higher keel line, deeper "V" of the hull and softer ride
- Sufficiently more space in the front of the cockpit
- Less water spray generation and drier ride, as on top speed the tube touches the water at the very end!

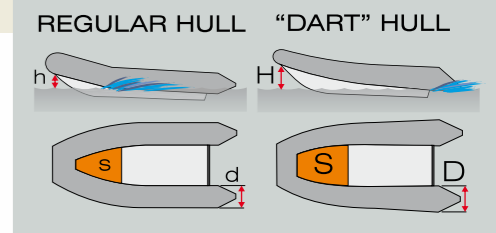

UNIQUE "HSH" DESIGN RIGID HULLS

The main concept behind our exclusive High-Step-Hull (HSH) is to increase buoyancy and ensure:

- the tube has less wetted surface during top speeds and planing over conventional boats,
- the tube offers excellent tracking during idle and slow speeds for superb maneuverability.

Every model with the HSH Hull system also affords:

- improved performance and less fuel consumption,
- a higher freeboard, along with increased buoyancy and load capacity,
- a smoother ride with comfort, safety and absolutely dry cockpit.

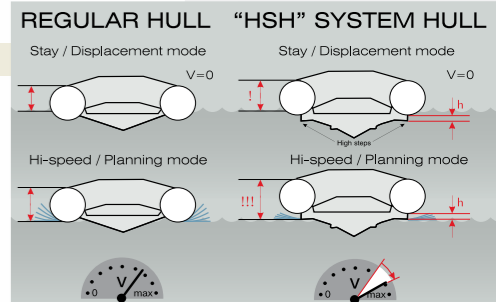



SILVER LINE Tenders

S250 • S275 • S300 • S300S • S330 • S330S



S300

Our SILVER LINE Tenders rank #1 in the rigid inflatable tender class by combining a traditional RIB design and our original styling. Stylish, light weight, very fast and spacious – SILVER LINE Tenders are Four main sizes are available including: 250 cm (8'2"), 275 cm (9'0"), 300 cm (10'10") and 330 cm (10'11").

Two platforms are also available:

- Base: A True Classic. A conventional tender featuring two removable wooden seats and oars, along with several functional appointments and optional equipment. Take it out for a shore island lunch or a short trip to the mainland for a few supplies.
- Sport: Treat the kids or yourselves. This platform comes equipped with GRAND's SPORT console featuring a complete steering system (except S250 and S275) and the ideal power options to qualify it as a potent and exciting high-speed watercraft. It's for boaters who value real fun and great handling! All models are available with PVC or HYPALON tubes.

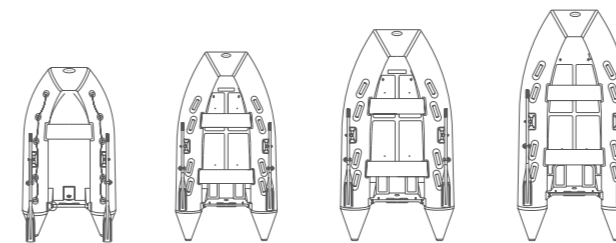

| | | | | |
|----------------------|----------------------------|-----------------------------|------------------------------|-------------------------------|
| Boat length, cm (ft) | 250 (8' 2") 6HP, 2 pers | 275 (9' 0") 10HP, 3 pers | 300 (9' 10") 15HP, 4 pers | 330 (10' 10") 20HP, 4 pers |
| BASE version | S250 | S275 | S300 | S330 |
| SPORT version | — | — | S300S | S330S |



S330S and S370S(black) with 9.9HP outboards

BASE version:



SPORT version:



S300

STANDARD FEATURES for BASE version:

- Medium "V" double-shell fiberglass hull
- 4 cross hull steps performance system (S300, S330)
- Flat antiskid deck surface
- 3 towing bow eyes
- Bow grab handle and two rear handles (S300, S330)
- 2 front and 2 rear st. steel lifting eyes
- Cockpit drain plug (bailer) and hull drain plug
- Soft curved multi-chamber buoyancy tube
- Tough raised rubbing strake with splash guard
- Safety grab handles (lifeline for S250)
- 2 oarlocks with 2 oars and oar posts
- Two removable wooden seats (one seat on S250)
- High efficiency foot pump
- Maintenance kit & User's manual

STANDARD FEATURES for SPORT version:

- Steering console Sport CS-01
- Inbuilt stainless steel fittings for the console
- Steering system with cable
- Steering wheel

OPTIONAL EQUIPMENT:

- Overall cover
- Bow stowage bag
- Overpressure valve
- Soft seat cushions with under-seat bag
- Keel protector and Tube protector packages
- Console cover (SPORT version)

PERFORMANCE CHART

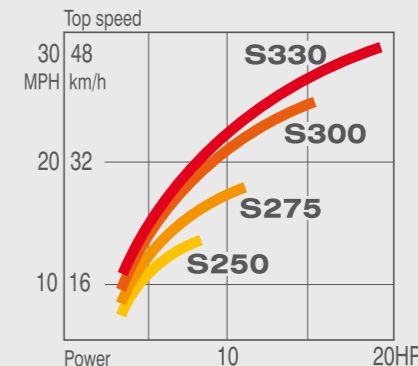

COLORS

LIGHT GRAY / GRAY (PVC and HYPALON)



WHITE / GRAY (PVC and HYPALON)



BLACK / GRAY (PVC only)



5 good reasons for choosing GRAND!



1. Unbeatable performance. Possibly the fastest RIB dinghies on the market!



2. The unique 4 hull steps system is fast and saves gas! (S300, S330 only).



3. Lowered tube ends for outstanding stability and an exceptionally dry ride!



4. Impressive carrying capacity with lots of cockpit space for your crew and staff.



5. Choose from a large selection of sizes to fit your swim platform.



SILVER LINE Riders

S370N • S420N



S420NL with navigation arch

S370N and S420N are the latest creation of GRAND, opening the new generation of mid-size RIBs. Both models are based on new original GRAND hull design concept: DART-HULL system with some great key features:

- exceptional stability with much softer ride and faster performance,
- impressive cockpit space with wider bow part, more seating and storage,
- extremely light-weight hull made of hand-laid high density GRP,
- unbeatable price for great value!

There are two models in the range including: 370 cm (12' 2"), 420 cm (13' 9") with three versions for each:

- BASE version (S370N, S420N) — boat with 2 wooden seats and oars,
 - SPORT version (S370NS, S420NS) — with CS-01 SPORT console for S370N, and with new CS-03 console for S420N,
 - DE LUXE version (S370NL, S420NL) — with new CL-11 DE LUXE steering console and rear double seat SD-06 with soft back and lockable container.
- Each model is available either with PVC or HYPALON buoyancy tube.

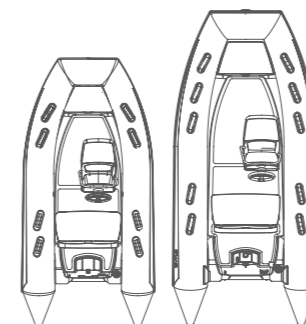

| | | |
|----------------------|------------------------------|------------------------------|
| Boat length, cm (ft) | 370 (12' 2") 30HP, 5 pers | 420 (13' 9") 50HP, 6 pers |
| BASE version | S370N | S420N |
| SPORT version | S370NS | S420NS |
| DE LUXE version | S370NL | S420NL |



S370N Black with optional navigation arch, bow step plate and fishing package

Fishing package:



S420NL

STANDARD FEATURES:

- Medium "V" double shell fiberglass hull with DART performance system and antiskid surface
- Molded-in large bow locker with access door
- Towing bow eye, 2 front and 2 rear lifting eyes
- Soft curved multi-chamber buoyancy tube
- Doubled draining system with 2 plugs and bailer
- Tough raised rubbing strake with splash guard
- Bow grab handle and safety grab handles
- Two wooden seats (BASE only)
- 2 paddles (SPORT, DELUXE), 2 oars + oarlocks (BASE)
- High efficiency foot pump
- Maintenance kit & User's manual

STANDARD FEATURES FOR DELUXE VERSION:

- CL-11 steering console with windshield, st steel railing, steering system, cable and steering wheel
- SD-06 double seat with soft seat, seat back and stowage
- Bow locker removable cushion

STANDARD FEATURES FOR SPORT VERSION:

- Steering console CS-01 (S370N)
- Steering console CS-03 with windshield and railing (S420N)
- Steering system with cable and steering wheel

OPTIONAL EQUIPMENT:

- Fiberglass step ends for inflatable tube
- Keel Protector and Tube Protector packages
- Overall cover, steering console cover
- Overpressure valve
- Bow locker removable cushion (BASE and SPORT)
- Folding stainless steel navigation arch
- Removable sundeck with soft cushion (S420NL)
- Collapsible bimini top
- Complete electric package
- Removable seat cushions with bag for S370N
- Fishing package for S370N, S420N, incl: bow step plate, with roller and cleat, rear anchor roller with cleat and 4 sets of fishing rod and cup holders on seats.

PERFORMANCE CHART



COLORS

LIGHT GRAY / GRAY (PVC and HYPALON)



WHITE / GRAY (PVC and HYPALON)



BLACK / GRAY (PVC only)



5 good reasons for choosing GRAND!



1. New generation of fast performing hulls with unique DART hull system from GRAND!



2. Spacious cockpit with wide bow locker, plenty of storage and comfortable seatings.



LIGHT-WEIGHT!
S370N - 80 kg (176 lbs)
S420N - 115 kg (253 lbs)

3. Lightest centre console boats on a market with double shell hand-laid GRP hulls.



4. Very practical and stylish steering console design for pleasant drive and complete control.



5. New system of folding stainless steel navigation arches for compact storage and low bridges pass.



SILVER LINE Riders

NEW

S470N • S470NS • S470NL



S470NLF with navigation arch and step ends

Silver Line S470N is the next new creation of GRAND, replacing the previous S470 — legendary GRAND bestseller. This model follows the new original philosophy of Silver Line models: practical, spacious and lightweight concept with elegant design, based on new and unique DART-hull system from GRAND. The key features of the new S470N are:

- wider boat with sufficiently more space in the cockpit and larger bow locker,
- exceptional stability and performance of DART-hull system and deeper "V" hull,
- low weight and excellent performance even with smaller engines,
- new generation steering console and double seat with more comfort, more storage space and high-class design.

There are three standard versions of S470N model:

- BASE version (S470N) — boat with empty cockpit to be custom equipped,
- SPORT version (S470NS) — boat with beautiful CS-03 SPORT console (jockey seat) and steering system,
- DELUXE version (S470NL) — boat with new steering console CL-14 with windshield, railing and front seat, and new slick SD-10 double seat.

Each model is available either with PVC or HYPALON buoyancy tube.



S470NS-SPORT



S470NLF (with step ends and navigation arch)

COMPARTMENTS CHART:

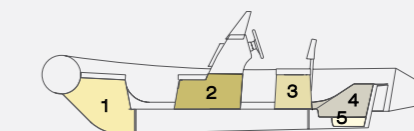

- 1 - Bow locker
- 2 - Console storage
- 3 - Double seat locker
- 4 - Rear open storage volume
- 5 - Water collector

PERFORMANCE CHART

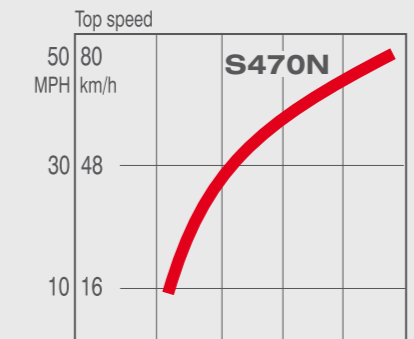

Performance data are approximate for boats loaded light.

COLORS

LIGHT GRAY / GRAY (PVC and HYPALON)



WHITE / GRAY (PVC and HYPALON)



BLACK / GRAY (PVC only)



S470NLF

STANDARD FEATURES FOR BASE VERSION:

- Deep-V hull with original "DART-hull" system
- Molded-in spacious bow locker with access door
- Towing bow eye, 2 front and 2 rear lifting eyes
- Cockpit drain plug (bailer) and hull drain plug
- Soft curved multi-chamber buoyancy tube
- Tough raised rubbing strake with splash guard
- Bow grab handle, safety grab handles
- 2 paddles and high efficiency foot pump
- Maintenance kit & User's manual

STANDARD FEATURES FOR SPORT VERSION:

- Steering console CS-03 with windshield and railing
- Steering system with cable and steering wheel

OPTIONAL EQUIPMENT:

- Fiberglass step ends of the inflatable tube
- Keel Protector and Tube Protector packages
- Overall cover, steering console and seat covers
- Overpressure valve
- Bow step plate with clam bollard
- Bow locker removable cushion (S470N and S470NS)
- Stainless steel folding navigation arch
- Removable sundeck for S470NL
- Collapsible bimini top
- Complete electric package

STANDARD FEATURES FOR DELUXE VERSION:

- Steering console CL-14 with windshield, railing, handrail, steering system, cable and steering wheel
- Rear double seat SD-10 with seat back and stowage
- Bow locker removable cushion.



5 good reasons for choosing GRAND!



1. Spacious cockpit with lots of storage and roomy bow locker.



2. Unique "DART hull" performance system with superior stability and dry ride.



3. Elegant and slick bow step plate with anchor roller and cleat (optional).



4. Wide and practical console dashboard for all your electronics, radio and stereo.



5. New very effective system of folding navigation arch for compact storage and low bridges pass.



SILVER LINE Riders

S520 • S520S • S520L



S520L with fiberglass step ends and navigation arch

S520 model is one of the last and most modern GRAND designs of rigid inflatable boats in mid-size range, which from its first day became an absolute bestseller as a family and cottage boat. The key points of its philosophy are: practical, spacious, easy transformable and nicely equipped boat for unbeatable price. Its really Deep-V hull (over 25° on transom and over 50° max) makes the boat a perfect rider on choppy water and sea waves. If you are looking for the reliable, roomy and easy transportable RIB for your family holiday — S520 is exactly what you need!

There are three versions of this model available:

- BASE version (S520) — boat with empty cockpit to be custom equipped,
- SPORT version (S520S) — boat with CS-03 SPORT console with windshield, railing and steering system,
- DE LUXE version (S520L) — boat includes new CL-12 DE LUXE steering console with windshield, railing, front seat and seatback and stowage compartment, and SD-02 rear double seat with st. steel polished railings, soft back and lockable container.

Each model is available with PVC or HYPALON buoyancy tube for your choice.



S520L
520 cm (17'1") long, 100HP, 9 pers



S520L with step ends and navigation arch

STANDARD FEATURES:

- Deep "V" molded fiberglass hull with self bailing cockpit, fuel tank compartment with access door
- Molded-in large bow locker (200 lit) with access door
- Towing bow eye, 2 front and 2 rear lifting eyes
- Two cockpit bailers and hull drain plug
- Soft curved multi-chamber buoyancy tube
- 2 rear cleats (excl. BASE)
- Tough raised rubbing strake with splash guard
- Bow grab handle, safety grab handles
- 2 paddles and high-efficiency foot pump
- Maintenance kit & User's manual

STANDARD FEATURES FOR DELUXE VERSION:

- CL-12 steering console with front seat and seat back, windshield and railing, two dashboards, steering system with cable and steering wheel
- Rear double seat SD-02 with st. steel polished railings, soft seatback and lockable stowage

STANDARD FEATURES FOR SPORT VERSION:

- CS-03 steering console with windshield and railing
- Steering system with cable and steering wheel

OPTIONAL EQUIPMENT:

- Fiberglass step ends of the buoyancy tube
- Keel Protector and Tube Protector packages
- Overall cover, steering console cover
- Overpressure valve
- Bow step plate with clam bollard
- Bow locker removable cushion
- Stainless steel polished navigation arch
- Removable sundeck
- Collapsible bimini top
- Complete electric package
- 90 liters built in fuel system with send and filler

PERFORMANCE CHART



COLORS

LIGHT GRAY / GRAY
(PVC and HYPALON)



WHITE / GRAY
(PVC and HYPALON)



BLACK / GRAY
(PVC only)



S520L-F



5 good reasons for choosing GRAND!



1. One of the deepest-V hulls on a market for exceptionally soft ride!



2. Huge bow locker (over 200 lit) for lots of stuff easily transforms to comfortable sundeck.



3. New CL-12 console with 2 large panels for lots of instruments and electronics.



4. High-profile large windshield with st. steel railing for excellent protection and more safety.



5. Fiberglass step ends — amazing optional feature for better performance and more fun!



SILVER LINE Cruisers

S550RF • S550GRF



S550GRF

SILVER LINE S550 is one of the GRAND models which may impress anyone with its fast increasing popularity. This long-awaited model within just one year became one of our bestsellers, winning the hearts of our customers. With developed modular design this boat became an ideal solution as a family boat for runabouts, watersports, cottaging and lots more. Being easy to transport and effectively powered, providing a plenty of storage space and cockpit area, showing incredibly high performance and stability with advanced deep-V hull, S550 became an unbeatable solution in the class of middle size RIBs!

Since 2013 every S550 comes with fiberglass step ends and polyester navigation arch as standard equipment under S550RF model name. It comes in two packages: DELUXE — basic package, and GRAND LUXE with some extra features. S550 is available either with PVC or HYPALON tube.



S550GRF (optional black tube)



S550GRF

5
STARS OF GRAND
5 good reasons for choosing GRAND!



1. Exceptional performance of the lightest and strongest hand-laid fibreglass hull!



2. Unique hull design with original "HSH" High Step Hull System for fast ride!



3. Large cockpit with lots of storage, sun-deck and unique tube-mount railing!



4. New generation steering console with two panels for instruments and electronics.



5. Unique GRP tube ends with practical steps for easy boarding, swimming and better ride!

STANDARD FEATURES:

- Heavy-duty Deep-V handlaid polyester hull
- Molded in bow locker with access door and soft cushion
- Rear locker with access door, soft seat and seat back
- Fiberglass step ends for inflatable tube
- Steering console CL-10 with windshield and railing
- Mechanical steering system with steering wheel and cable
- Front storage locker with hatch, lifters and cushion
- Bow towing eye and 4 lifting eyes
- Polyester navigation arch
- 2 rear pull up stainless steel cleats
- Bow step plate with anchor roller, 2 fairleads and pull-up cleat
- Built-in 90-lit fuel tank with filler and send
- Main deck access door with inspection hatch
- 2 paddles, user's manual and foot pump

GRAND LUXE FEATURES:

- Stainless steel bow railing and 2 rear handrails
- Electric package
- Two swim platforms with ladder

OPTIONAL EQUIPMENT:

- Removable bow sundeck with cushions
- Water shower set with 50-lit tank, pump, shower
- Overall cover, console cover
- Hydraulic steering system with steering wheel
- Bimini-top
- Keel and tube protection system
- Overpressure valve
- Waterski towing mast

PERFORMANCE CHART



COLORS

- LIGHT GRAY / GRAY (PVC and HYPALON)
- WHITE / GRAY (HYPALON only)
- BLACK / GRAY (PVC only)

COMPARTMENTS CHART

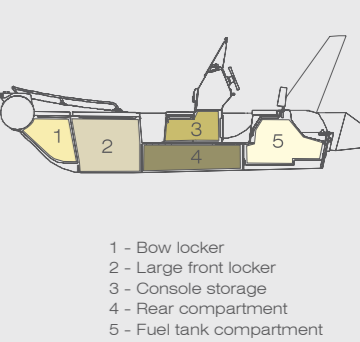



SILVER LINE Cruisers

S650LF • S650GLF



S650GLF

Our SILVER LINE Cruiser S650 is one of our bestselling models in a new series cruising and offshore rigid inflatable boats. This rigid weapon is considered one of the top models in the international RIB arena with its outstanding seaworthiness, unique design, practical cockpit arrangement and impressive capacities. Boaters will certainly appreciate its many benefits including a spacious cockpit with comfortable seating places and plenty of storage space for safety equipment or gear. What's even more impressive is it utilizes GRAND's exclusive HSH-hull system and a range of power choices to deliver exceptional performance. Better yet, it's practical enough, comfortable enough and elegant enough to claim it as the best boat in its class! Every boat is equipped with standard fiberglass step ends with very practical design. They have a large step with antiskid surface, where you can stand or even sit on it — excellent feature for a first choice boat!



SILVER LINE S650GLF



S650GLF

COMPARTMENTS CHART

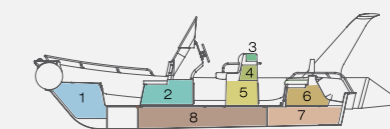

- 1 - Bow locker
- 2 - Console storage
- 3 - Seating bar upper locker
- 4 - Seating bar locker with table
- 5 - Seating bar lower locker
- 6 - Rear dry compartment
- 7 - Rear lower compartment
- 8 - Fuel tank compartment

STANDARD FEATURES:

- Heavy-duty Deep-V rigid polyester hull with HSH system
- Molded-in bow locker with access door and soft cushion
- Rear locker with access door, soft seat and seat back
- Bow towing eye and 4 lifting eyes
- Steering console CL-15 (NEW) with windshield and railing
- Bow locker removable cushion
- SD-04 pilot bar with 3 lockers and folding table
- Bow step plate with anchor roller, 2 fairleads and pull-up cleat
- 2 rear pull up stainless steel cleats
- Polyester navigation arch
- Built-in 140-lit fuel tank with filler, and send
- Main deck access door with inspection hatch
- 2 folding paddles and manual foot pump

GRAND LUXE VERSION FEATURES:

- Stainless steel bow railing
- 2 rear seat extended handrails
- Two swimming platforms with folding ladder
- Complete electric package

OPTIONAL EQUIPMENT:

- Overpressure valve
- Removable bow sundeck with cushions
- Set of 2 captain swivel adjustable chairs
- Shower set with 50-lit tank, pump and shower
- Overall cover, console cover, pilot bar cover
- Hydraulic steering system
- St. console head for side mount control box
- 3-arch stainless steel bimini top
- Keel and tube protection packages
- Waterski towing mast

PERFORMANCE CHART

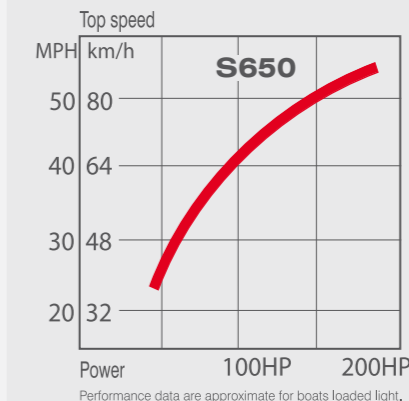

COLORS

LIGHT GRAY / GRAY (PVC and HYPALON)



WHITE / GRAY (HYPALON only)



BLACK / GRAY (PVC only)



S650GL with sundeck (optional)



5 good reasons for choosing GRAND!



1. Best performer in its class with lightest and strongest hand-laid GRP "Deep-V" hull!



2. Unique hull design with original "HSH" High Step Hull System! Unbeatable solution!



3. The most spacious cockpit with lots of storage, sundeck space and unique railings!



4. New steering console CL-15 with two beautiful metallic-decorated dashboards.



5. Unique GRP tube ends with large and practical steps for easy boarding, swimming and better ride!



GOLDEN LINE

Cruisers

NEW

G650LF • G650GLF



G650LF with bow railing and waterski arch

The Golden Line G650 is a new breathtaking creation of GRAND, presenting absolutely new and unique concept of rigid inflatable boat with several fantastic ideas and features, which make this model a remarkable event in the world of boating. Just have a look at some of them:

- U-form rear seat (sofa) — this feature is common for larger RIBs, but this is the first time when it is so nicely arranged on 6.5m long RIB,
- Rounded bow part of the tube — unique and recognizable shape with nice touch of elegance and beauty in boat lines,
- New concept of steering console with impressive spacious dashboard,
- Elegant driver's console with folding seats and railings,
- Innovative waterski towing arch, combining the features of navigation arch and wakeboard or waterski towing capability.

But after all that the New Golden Line G650 is the most beautiful boat, ever created by GRAND and we believe it will become the most beloved one by our GRAND Customers.

The boat is available either with PVC or HYPALON tubes.

G650LF

with white or light gray tube, optional teak decking, white or buff (beige) upholstery

G650LFB

with black tube, optional teak decking, gray upholstery



G650LF with bow railing and waterski arch

COMPARTMENTS CHART

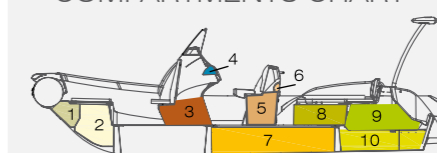

- 1 - Bow anchor storage
- 2 - Bow locker
- 3 - Console storage
- 4 - Gloves box with hatch
- 5 - Double seat storage
- 6 - Seat storage shelf
- 7 - Fuel tank compartment
- 8 - Two side storage boxes
- 9 - Main rear storage
- 10 - Lower rear storage

PERFORMANCE CHART

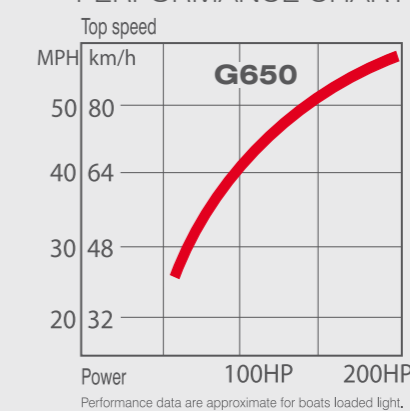

COLORS

LIGHT GRAY / GRAY (PVC and HYPALON)



WHITE / GRAY (HYPALON only)



BLACK / GRAY (PVC only)

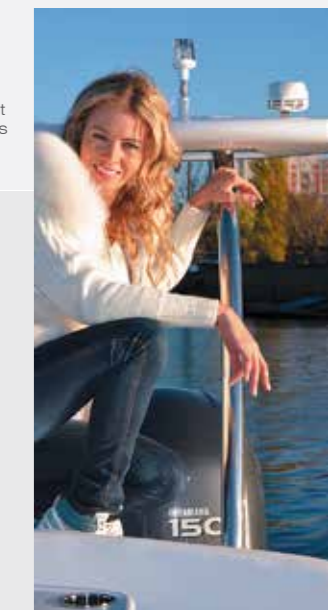

5 good reasons for choosing GRAND!



1. U-form sofa rear seat with comfortable seat back and two side railings.



2. Deep-V hull with transom extensions for superior performance and soft ride.



3. High-end steering console design for 12" GPS and all electronics.



4. Transom extensions, GRP step ends and swim platforms for performance and comfort.



5. Elegant and easy-to-store removable table with deck-mount pedestal and 4 cup holders.

STANDARD FEATURES FOR DELUXE VERSION:

- Deep-V fiberglass hull with transom extensions, bow towing eye and self-bailing cockpit
- "DART" system inflatable tube with GRP step ends
- Bow locker with anchor compartment and hatch
- Bow step plate with nav. lights, anchor roller and cleat
- Steering console CL-16 with front seat, windshield, railing, front rails, handle and gloves box
- Driver's double seat SD-11 with two folding seats
- U-form rear seat / sofa with 2 side lockers, soft cushions and high seatback
- Rear locker with large access door and gas springs
- Rear railings, two rear cleats and two towing eyes
- Built-in fuel system with 200 lit fuel tank and send
- 2 front and 2 rear liftig eyes
- Maintenance kit, pump, 2 paddles and manual.

STANDARD FEATURES FOR GRAND LUXE VERSION:

- Two swimming platforms with folding ladder
- Electric package with nav. lights, bilge pump, electric horn, switches, battery switch and complete wiring
- Stainless steel bow railing

OPTIONAL EQUIPMENT:

- Bow sundeck, rear sundeck and rear sundeck extension
- Keel and tube protector packages
- Waterski towing arch with towing eye and GRP top
- Removable table with 4 cup holders
- Overall cover, consoles and rear seat covers
- Water shower set with pump and 50-lit tank
- Collapsible stainless steel bimini top
- PVC teack decking
- SUNBRELLA upholstery upgrade
- Overpressure valve

Golden Line 6650

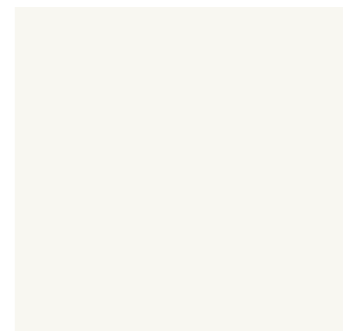
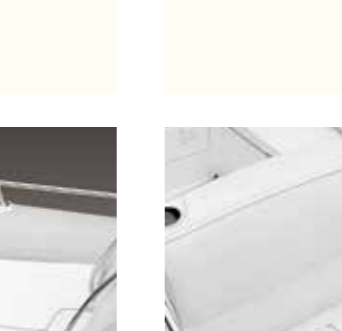
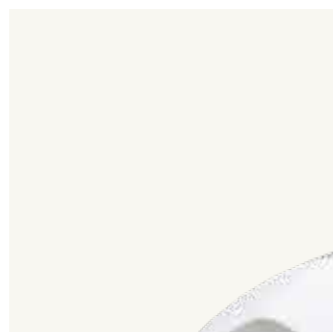

NEW 2014



GOLDEN LINE Riders

G480LF • G480EF



G480LF

The GOLDEN LINE Rider pushes the envelope in contemporary naval architecture and engineering. But it's also about Elegance and Prestige. It opens an entirely new door in design and revolutionizes an entire class. With a long list of standard features, along with a thoughtful and impressive options list, this entry will undoubtedly serve the needs of versatile, adventurous boaters. And with its first-rate performance, good looks and plush comfort, the GOLDEN LINE Rider delivers the highest level of luxury boating, offering a first-class seat to enjoy the world in style!

The series now is represented with the model G480 with LOA 480 cm (16') in two versions with the choice of HYPALON or MIRASOL tubes:

- DE LUXE version (G480LF) — high-profile boat for cruising and watersports, equipped with high-profile console with windshield and st. steel navigation arch.
- ELITE version (G480EF) — low-profile boat as a yacht tender, equipped with low-profile steering console and two st. steel side railings.

Both models have a unique and best selling feature: fiberglass step ends of the inflatable tube, with large steps for easy boarding and swimming.



G480EF with optional waterski towing mast



G480LF

COMPARTMENTS CHART

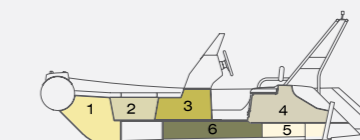

- 1 - Bow locker
- 2 - Bow side storage
- 3 - Console storage compartment
- 4 - Rear dry compartment
- 5 - Lower bilge compartment
- 6 - Fuel tank compartment

PERFORMANCE CHART

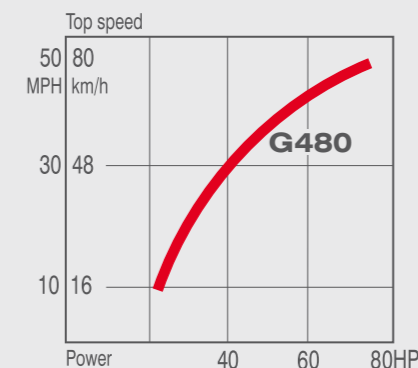

COLORS

LIGHT GRAY / GRAY (PVC and HYPALON)



WHITE / GRAY (PVC and HYPALON)



BLACK / GRAY (PVC only)



Large dashboard for lots of electronics

STANDARD FEATURES:

- Deep "V" hand-laid fiberglass hull with HSH system, transom extensions and spray protection system
- Antiskid deck surface, hull drain plug and hull vents
- Towing bow eye, 1 front and 2 rear lifting eyes
- 2 rear pull-up cleats
- Cockpit drain system with one-way drain valve
- Fiberglass step ends of inflatable tube
- Soft curved multi-chamber buoyancy tube
- Doubled tough raised rubbing strake with splash guard
- Bow grab handle and board safety grab handles
- Molded-in bow and rear stowages with cushions
- High-profile seating console with windshield and st. steel railing (G480LF)
- Low-profile steering console with handle (G480EF)
- Steering system with cable and steering wheel
- Wide bow step plate with pull-up cleat and navigation light
- Stainless steel navigation arch with 2 handrails (G480LF)

- 2 stainless steel side railings for rear seat (G480EF)
- 2 paddles, Footpump, Maintenance kit & User's manual

STANDARD FEATURES FOR GRAND LUXE VERSION:

- Battery container, disconnect and battery wire
- Main boat cable, 3 marine switches with fuses
- Navigation lights, electric horn
- Automatic bilge pump with drain pipe
- Electric accessory socket (phone charge plug)
- Inbuilt fuel tank 55 lit with filler, vent and send

OPTIONAL EQUIPMENT:

- St. steel waterski towing mast
- Keel and Tube Protectors
- Overpressure valve
- Overall cover, steering console cover
- Removable sundeck with cushion, Bimini top
- Removable bow table



5 good reasons for choosing GRAND!



1. Exceptional performance, with a smooth and dry ride even on high waves!



2. HSH hull system and transom extensions are the key features of this unique design.



3. Spacious and elegant cockpit provides a lot of sunbathing space and storage.



4. This boat is great for all kind of activities and watersports!



5. Standard GRP tube ends with large steps for easy boarding and better ride!



GOLDEN LINE Tenders

G340EF • G380EF



G340EF with optional teack deck

Since their launch in the marine industry, our GOLDEN LINE Tenders introduced a new age of luxury RIB design. With superior quality, comfort and elegance, this series has become a prestigious and exclusive tender for owners of luxury yachts. Every model boasts a unique water spray protection system that is designed to provide a dry ride with no water entering from the stern. There are currently two main sizes: 330cm (10'10") and 360cm (11'10") with fiberglass step ends - fully equipped boat with larger bow step plate with navigation light, pull up cleat and soft seat back, low profile console with handrail, and two rear railings. But the most unique feature is their unbeatably low weight, what makes them fitting any, even low capacity, lifting system:

- G340EF: boat weight = 115kg (253 lbs), boat+20HP motor = 190kg (418 lbs),
 - G380EF: boat weight = 170kg (374 lbs), boat+40HP motor = 265kg (583 lbs).
- GOLDEN LINE Tenders are available with MIRASOL or HYPALON tubes. Experience what a real magnificent pastime boating is!



G380EF

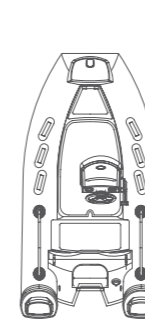

G340EF
25HP, 4 people
330 cm (10'10")

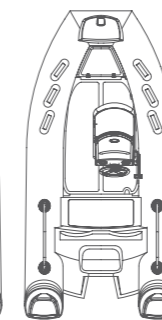

G380EF
40HP, 5 people
360 cm (11'10")



G380EF

COMPARTMENTS CHART

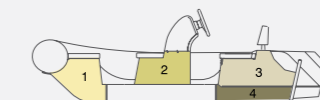

- 1 - Bow locker
- 2 - Console storage compartment
- 3 - Rear dry compartment
- 4 - Rear lower compartment

STANDARD FEATURES:

- Medium "V" hull with extended transom plates
- 3 towing bow eyes, 2 front + 2 rear lifting eyes, 2 rear cleats
- Cockpit drain system with one-way drain valve
- Soft curved tube with 3 chambers
- Tough raised rubbing strake with splash guard
- Bow grab handle and board safety grab handles
- Molded-in lockable bow stowage with cushion
- Molded-in rear lockable seat with cushion and seat back
- Steering system with cable and steering wheel
- High efficiency foot pump and 2 paddles
- Extended bow step plate with pull-up cleat, navigation light and soft bow seat back
- Low profile steering console with handle, folding head and front seat (G380EF) with removable cushion
- 2 rear safety handrails
- Fiberglass step ends of inflatable tube

GRAND LUXE PACKAGE FEATURES:

- Battery container, disconnecter and battery wire
- Main boat cable
- 3 marine switches set with fuses
- Navigation lights
- Bilge Pump with drain system
- Electric accessory socket (phone charge plug)

OPTIONAL EQUIPMENT:

- Keel and Tube protection packages
- Built-in fuel system with 40 liters tank and send (NEW)
- Boat overall cover and steering console cover
- Close cell foam upgrade for all cushions
- Collapsible bimini-top
- Overpressure valve

PERFORMANCE CHART



COLORS

LIGHT GRAY / GRAY (PVC and HYPALON)



WHITE / GRAY (PVC and HYPALON)



BLACK / GRAY (PVC only)



G380EF



5 good reasons for choosing GRAND!

LOWEST WEIGHT!



1. LIGHTEST LUXURY DINGHIES EVER !!! Boat weights: G340 - 115 kg, G380 - 170 kg!



2. Elegant transom extensions for a better ride, stability, Flotation and easily getting on plane!



3. Fastest performing hull designs: G340 - 4 cross steps, G380 - HSH system.



4. Adjustable rear seat back with maximum height up to 400 mm (15") for your comfort!



5. Unique GRP tube ends with large and practical steps for easy boarding, swimming and better ride!



RANGER

Sport & PRO Boats

R380 • R420 • R460



R420 with steering console CS-02 (optional)

The RANGER series are heavy-duty, foldable, inflatable boats specially designed for water sports and demanding applications. With their superior strength, technology, hydrodynamics and GRAND's expertise, the RANGER is a tough model that guarantees the utmost Safety, Stability and Power! They can readily pull double-duty for demanding, professional on-water applications or ideally serve recreational boaters who fish, dive, waterski or cruise with the family, even under the harshest sea conditions.

There are three models in the range: 380 cm(12'6"), 420 cm (13'9") and 460 cm (15'1") and each of them can be upgraded to solid wooden keel (optional) from the inflatable one, or PRO-grade fabric for professional applications. A Real Boat for the Real Man!

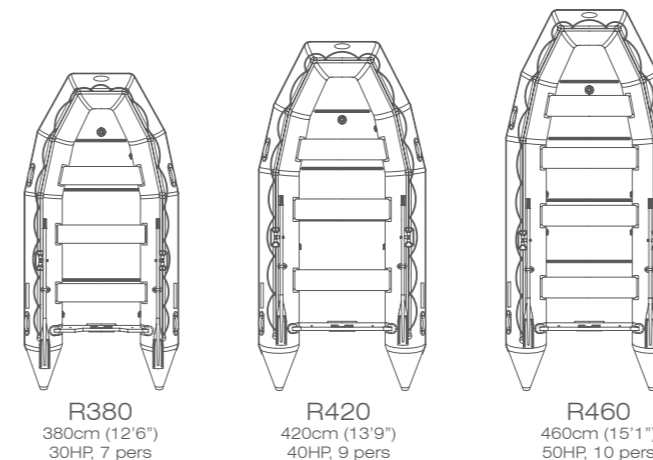

R420 with steering console CS-02

STANDARD FEATURES:

- Medium-V bottom
- Marine grade plywood floorboards with inflatable keel
- Anodized aluminum reinforcement system
- Reinforced integral transom for outboard engine
- 3 reinforced towing bow eyes
- Cockpit drain plug (bailer)
- Multi-chamber buoyancy tube
- Tough raised rubbing strake with splash guard
- 3 removable wooden seats (4 on R460)
- Substantial safety life line with line bar
- Bow grab handle
- 2 side and 2 rear lifting handles
- 2 oarlocks with 2 oars and oar posts
- 2 Carry bags
- High efficiency foot pump
- Maintenance kit & User's manual

OPTIONAL EQUIPMENT:

- Steering console CS-02 with steering system, steering wheel, cable and installation system
- Boat overall cover
- Overpressure valve
- Soft seat cushions with underseat bags
- Keel and Tube Protection package
- Wooden keel with solid installation system
- Upgrade to HEAVY DUTY material (1400 g/sq.m.)
- Collapsible bimini-top

PERFORMANCE CHART



COLORS

- LIGHT GRAY (PVC)
- GREEN (PVC)
- BLACK (PVC)



R420



5 good reasons for choosing GRAND!



1. Toughest boat for military, patrol, rescue, and other professional applications!



2. Spacious cockpit with easy to install wooden seats and antiskid floorboards.



3. Perfect choice for fishing, diving and a great cottage boat.



4. It perfectly fits a trailer, being always ready for any occasion, even firefighting!



5. Lowered tube ends stabilize the boat at fast speed and make the ride dry.



CORVETTE

Sport Boats

C240 • C270 • C300 • C330 • C360



C330

There's no limit to practicality and excitement with GRAND's Corvette series of foldable tenders. An excellent choice for any yachtsmen, the CORVETTE series feature a traditional design, GRAND's original styling, and are light, spacious and easily portable whether they are stowed away or ready to run. They also have impressive agility and load capacities, making them the perfect model for fishing, camping and family fun!

Five base models are available ranging from 240 cm (8') to 360 cm (12'), with two versions:

- Strong marine-grade plywood floorboards with heavy-anodized aluminum reinforcement (C240-C360),
- Modern and light high-pressure inflatable floor/air deck (C240A-C360A).

All you have to do is choose the right size for your activity and let it rip!

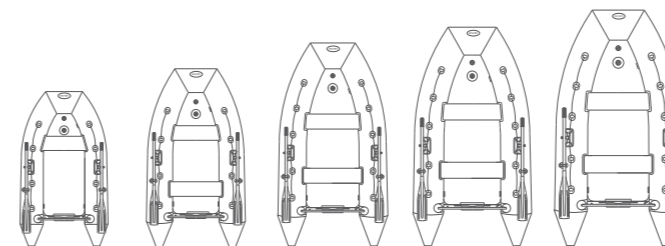

| Boat length, cm (ft) | 240 (7' 10") 5HP, 2 pers | 270 (8' 10") 10HP, 3 pers | 300 (9' 10") 15HP, 4 pers | 330 (10' 10") 20HP, 4 pers | 360 (11' 10") 30HP, 5 pers |
|----------------------|-----------------------------|------------------------------|------------------------------|-------------------------------|-------------------------------|
| FLOORBOARDS | C240 | C270 | C300 | C330 | C360 |
| AIRDECK | C240A | C270A | C300A | C330A | C360A |



C330



5 good reasons for choosing GRAND!



1. All models easily get on plane and are fast performing even with small motors.



2. V-shaped transom with original metal reinforced installation system.



3. Substantial inflatable keel for a solid performance on rough waters.



4. Optional overpressure valve to protect against pressure and temperature extremes.



5. Compact and low weight design for simple and efficient assembling.

STANDARD FEATURES:

- Medium "V" bottom and "V"—shaped transom
- Antiskid marine ply floorboards with aluminum reinforcement and inflatable keel (C240-C360)
- High-pressure air deck with inflatable keel (C240A-C360A)
- Soft-curved collar with 3 chambers
- Integral transom for outboard engine
- 3 towing bow eyes
- Cockpit one way drain valve (bailer)
- Tough raised rubbing strake with splash guard
- Safety life line
- Bow grab handle
- Two rear grab handles (C300, C300A-C360, C360A)
- 2 oarlocks with 2 oars and oar posts
- 2 removable wooden seats (1 on C240, C240A)
- High-efficiency foot pump for C240-C360
- 2 Chamber high-pressure pump for C240A-C360A

- One carry bag for C240, C270 and two carry bags for C300-C360
- Substantial keel protector
- Maintenance kit & User's manual

OPTIONAL EQUIPMENT

- Front & rear soft cushions (close-cell foam) with the removable under-seat bags
- Overall cover
- Overpressure valve
- Tube and keel protection package

PERFORMANCE CHART

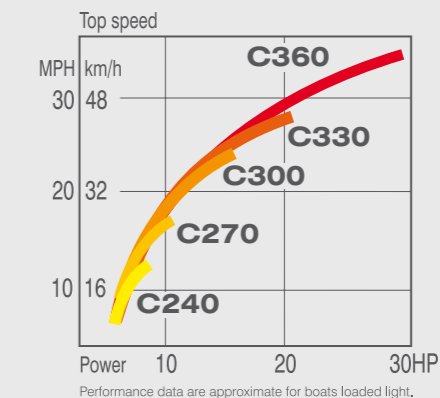

COLORS

- LIGHT GRAY / GRAY (PVC only)
- WHITE / GRAY (PVC only)
- BLACK / GRAY (PVC only)



C360



ELF Foldable Dinghies

E210 • E240 • E270 • E300



E270

The ELF series is the perfect example that great things come in small packages. The ELF models are small and light inflatable dinghies that are ready to perform when the duty calls. A top choice for owners of sailboats and motoryachts, models in the ELF series are compact, easy to use and assemble. They are also tough as nails to provide years of use. In addition to impressive capacities and slatted flooring with extremely low maintenance, every ELF is featured-packed and designed to provide the utmost safety and stability. They are the perfect choice for camping and a reliable model to introduce your children to the exciting world of boating.

The ELF series includes four models from 210 cm (7') to 300 cm (10') with slatted deck, which is light, easy to pack and maintain, and safe to use. And each of them is easy to Ride, easy to Row, easy to Carry, easy to Tow!

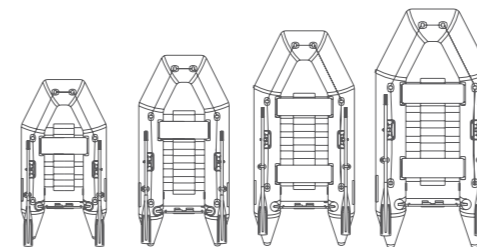

| Model | E210 | E240 | E270 | E300 |
|----------------|-----------------|-----------------|-----------------|-----------------|
| Length overall | 210 cm (6' 11") | 240 cm (7' 10") | 270 cm (8' 11") | 300 cm (9' 10") |
| Engine max | 4HP max | 5HP max | 8HP max | 10HP max |
| Passengers | 2 persons | 3 persons | 3 persons | 4 persons |



E270



5 good reasons for choosing GRAND!



1. All boats are easy to carry and are light weight, starting from only 18kg for E210.



2. All models are very compact and can fit a trunk of any car.



3. The most simple, easy to use and reliable wooden seat installation system.



4. Uniquely designed lifeline, which is always tight and will never get loose.



5. Extended and lowered down tube ends are an excellent feature for more flotation and stability.

STANDARD FEATURES:

- Multi chamber buoyancy tube
- Integral marine grade ply transom
- Slatted deck bottom on E210-E300
- 2 oarlocks with 2 oars and oar posts
- 3 towing bow eyes
- Cockpit drain valve (one-way bailer)
- Rubbing strake with splash guard
- Safety life line
- Bow grab handle
- High efficiency foot pump
- Two removable wooden seats (1 seat on E210, E240)

- Carry bag
- Maintenance kit & User's manual

OPTIONAL EQUIPMENT:

- Overall cover
- Soft seats with removable under-seat bags
- Overpressure valve

PERFORMANCE CHART

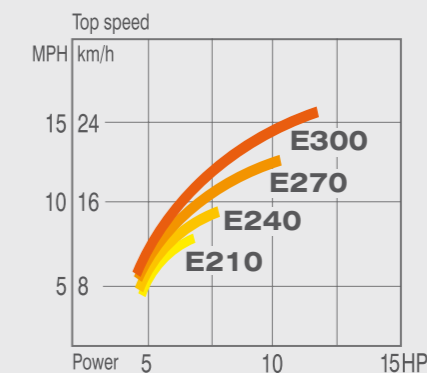

COLORS

LIGHT GRAY (PVC)

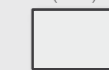

GREEN (PVC)



E240



ARGUS Foldable Canoes

A380 • A450 • A550



Our new series of inflatable canoes ARGUS are an outstanding example of combining the superior buoyancy, stability and performance of inflatables with the idea of the classic canoe. They are excellent for relaxed paddling or extreme exploration of remote places in wild nature. Oars or paddles, an outboard motor or a sailing kit- all the propulsion means are available, along with different options of seating for your very own comfort.

There are three sizes (380 cm, 450 cm, 550 cm) for 2, 3, and 4 passengers and 2 versions: DISCOVERY (basic version) and PRO (with extra features). Starting from season 2014 we are happy to offer three unique features:

- Adjustable rail-based sliding seats system,
- Two water deflectors in the front for splash protection on high speed,
- Two low profile stability skegs in the rear for extra tube protection.



A380

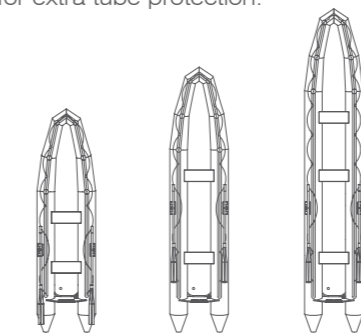

A380 380cm (12'6") 5HP, 2 pers
 A450 450cm (14'9") 6HP, 3 pers
 A550 550cm (18'1") 8HP, 4 pers



Adjustable rail-based sliding seats system



A380

Two bow deflectors for splash protection



Two new low-profile skegs in the rear



A380 on plane with outboard motor



STANDARD FEATURES (Discovery and PRO):

- Multi chamber buoyancy tube with lowered cones
- Integral marine grade plywood transom
- Cockpit drain valve (one-way bailer)
- Removable high-pressure airdeck
- Stainless steel towing eye
- 2 rear carry handles
- Tube extra protectors at the bow
- Safety life line around the perimeter
- 2 rear T-form fins for directional stability
- Original rail-based sliding system for wooden seats
- 2 (A380, A450) or 3 (A550) removable wooden seats

- 2 front water deflectors for splash protection
- Two chamber high-pressure foot pump
- Carry bag
- Maintenance kit & User's manual

STANDARD EQUIPMENT FOR PRO VERSION:

- T-form lifeline bar to increase freeboard
- 2 oarlocks with 2 oars and oar posts

PERFORMANCE CHART

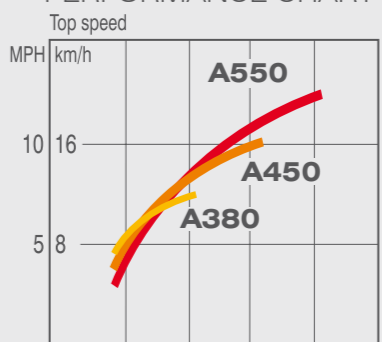

COLORS

- LIGHT GRAY / BLUE (PVC)
- GREEN (PVC)



5 good reasons for choosing GRAND!



Portable and light

1. Amazingly light (from 20kg) and portable to fit a half of your car trunk!



5 min to assemble

2. Easy to carry in the bag and very fast to assemble in just 5 min!



Easy to handle

3. Easy handling, great performance and tracking with two oversize fins!



Solid and stable

4. Solid and robust hull structure and superior stability for rapids and even wide-water use!



Roomy and versatile

5. Roomy cockpit with impressive load capacity and integral transom for lots of power.

TECHNICAL DATA SPECIFICATION

Rigid Inflatable Boats (RIB)

Foldable Inflatable Boats

| Series | | SILVER LINE Tenders | | | | SILVER LINE Riders | | | | | | | SILVER LINE Cruisers | | GOLDEN LINE Series | | | | | RANGER Series | | | CORVETTE Series | | | | | ELF Series | | | | ARGUS Series | | | |
|---------------------------|-----------|---------------------|------------|----------------|----------------|--------------------|------------|------------------|--------------|------------------|-----------|----------------|----------------------|-----------|--------------------|------------|-----------|-----------|-----------|---------------|------------|-----------|-----------------|-----------------|-----------------|-----------------|-----------------|-----------------|------------|-------------|-------------|--------------|----------------|----------------|----------------|
| Models | | S250 | S275 | S300/ S300S | S330/ S330S | S370N/ S370NS | S370NL | S420N/ S420NS | S420NL | S470N/ S470NS | S470NL | S520/ S520S | S520L | S550RF | S650LF | G340EF | G380EF | G480LF | G480EF | G650LF | R380 | R420 | R460 | C240 / C240A | C270 / C270A | C300 / C300A | C330 / C330A | C360 / C360A | E210 | E240 | E270 | E300 | A380/ A380P | A450/ A450P | A550/ A550P |
| Length overall | cm | 250 | 275 | 300 | 330 | 370 | 370 | 420 | 420 | 470 | 470 | 520 | 520 | 540 | 630 | 330 | 360 | 455 | 455 | 650 | 380 | 420 | 460 | 240 | 270 | 300 | 330 | 360 | 210 | 240 | 270 | 300 | 380 | 450 | 550 |
| | ft/inches | 8' 2" | 9' 0" | 9' 10" | 10' 10" | 12' 2" | 12' 2" | 13' 9" | 13' 9" | 15' 5" | 15' 5" | 17' 1" | 17' 1" | 17' 9" | 20' 8" | 10' 10" | 11' 10" | 14' 11" | 14' 11" | 21' 4" | 12' 6" | 13' 9" | 15' 1" | 7' 10" | 8' 10" | 9' 10" | 10' 10" | 11' 10" | 6' 11" | 7' 10" | 8' 10" | 9' 10" | 12' 6" | 14' 9" | 18' 1" |
| Length inside | cm | 166 | 182 | 200 | 218 | 270 | 270 | 310 | 310 | 340 | 340 | 385 | 385 | 415 | 508 | 240 | 270 | 340 | 340 | 440 | 265 | 300 | 340 | 165 | 187 | 205 | 235 | 255 | 135 | 165 | 184 | 200 | 300 | 370 | 470 |
| | ft/inches | 5' 5" | 6' 0" | 6' 7" | 7' 2" | 8' 10" | 8' 10" | 10' 2" | 10' 2" | 11' 2" | 11' 2" | 12' 8" | 12' 8" | 13' 7" | 16' 8" | 7' 10" | 8' 10" | 11' 2" | 11' 2" | 14' 5" | 8' 8" | 9' 10" | 11' 2" | 5' 5" | 6' 2" | 6' 9" | 7' 9" | 8' 4" | 4' 5" | 5' 5" | 6' 0" | 6' 7" | 9' 10" | 12' 2" | 15' 5" |
| Width overall | cm | 146 | 155 | 167 | 195 | 185 | 185 | 195 | 167 | 220 | 220 | 220 | 255 | 265 | 176 | 186 | 210 | 210 | 265 | 190 | 205 | 205 | 190 | 155 | 165 | 165 | 184 | 130 | 130 | 145 | 160 | 100 | 100 | 104 | |
| | ft/inches | 4' 9" | 5' 1" | 5' 6" | 5' 7" | 6' 1" | 6' 1" | 6' 4" | 6' 4" | 6' 9" | 6' 11" | 7' 3" | 7' 3" | 8' 4" | 8' 8" | 5' 9" | 6' 1" | 6' 11" | 6' 11" | 8' 8" | 6' 3" | 6' 9" | 6' 9" | 4' 7" | 5' 1" | 5' 5" | 5' 5" | 6' 0" | 4' 3" | 4' 3" | 4' 9" | 5' 3" | 3' 3" | 3' 3" | 3' 5" |
| Width inside | cm | 62 | 70 | 78 | 78 | 92 | 92 | 101 | 101 | 100 | 110 | 115 | 115 | 145 | 150 | 80 | 88 | 105 | 105 | 150 | 95 | 105 | 105 | 69 | 73 | 78 | 78 | 90 | 57 | 57 | 66 | 77 | 40 | 40 | 40 |
| | ft/inches | 2' 0" | 2' 4" | 2' 7" | 2' 7" | 3' 0" | 3' 0" | 3' 3" | 3' 3" | 3' 3" | 3' 3" | 3' 9" | 3' 9" | 4' 9" | 4' 11" | 2' 7" | 2' 11" | 3' 5" | 3' 5" | 4' 11" | 3' 1" | 3' 5" | 3' 5" | 2' 3" | 2' 5" | 2' 7" | 2' 7" | 2' 11" | 1' 10" | 1' 10" | 2' 2" | 2' 6" | 1' 4" | 1' 4" | 1' 4" |
| Tube diameter | cm | 38 | 40 | 43 | 43 | 46 | 46 | 46 | 46 | 50 | 50 | 50 | 50 | 55 | 55 | 43 | 46 | 50 | 50 | 55 | 46 | 48 | 48 | 36 | 40 | 43 | 43 | 46 | 34 | 34 | 37 | 40 | 30 | 30 | 32 |
| | inches | 15" | 16" | 17" | 17" | 18" | 18" | 18" | 18" | 20" | 20" | 20" | 20" | 22" | 22" | 17" | 18" | 20" | 20" | 22" | 18" | 19" | 19" | 14" | 16" | 17" | 17" | 18" | 13" | 13" | 15" | 16" | 12" | 12" | 13" |
| Bare Boat weight * | kg | 46 | 53 | 56 / 77 | 63 / 84 | 95 / 120 | 124 | 115 / 145 | 145 | 170 / 200 | 208 | 225 / 255 | 285 | 440 | 622 | 129 | 170 | 250 | 234 | 750 | 78 | 88 | 102 | 29 / 24 | 45 / 32 | 54 / 33 | 60 / 36 | 73 / 42 | 18 | 21 | 24 | 29 | 19 / 24 | 22 / 27 | 30 / 36 |
| | lbs | 101 | 117 | 123 / 169 | 139 / 185 | 209 / 264 | 273 | 253 / 319 | 319 | 374 / 440 | 458 | 495 / 561 | 627 | 968 | 1368 | 284 | 374 | 550 | 515 | 1650 | 172 | 194 | 224 | 64 / 53 | 99 / 70 | 119 / 73 | 132 / 79 | 161 / 92 | 40 | 46 | 53 | 64 | 42 / 53 | 48 / 59 | 66 / 79 |
| Transport gross weight ** | kg | 72 | 87 | 91 / 112 | 99 / 119 | 158 / 184 | 185 | 178 / 209 | 209 | 226 / 256 | 265 | 285 / 320 | 350 | 540 | 780 | 195 | 235 | 325 | 317 | 860 | 97 | 110 | 134 | 34 / 29 | 49 / 37 | 59 / 38 | 65 / 41 | 78 / 47 | 27 | 28 | 35 | 40 | 27 / 33 | 30 / 35 | 38 / 44 |
| | lbs | 158 | 191 | 200 / 246 | 218 / 262 | 348 / 405 | 407 | 392 / 460 | 460 | 497 / 563 | 583 | 627 / 704 | 770 | 1188 | 1716 | 429 | 517 | 715 | 697 | 1892 | 213 | 242 | 295 | 75 / 64 | 108 / 81 | 130 / 84 | 143 / 90 | 172 / 103 | 59 | 62 | 77 | 88 | 59 / 70 | 66 / 78 | 84 / 97 |
| Loading capacity*** | kg | 330 | 440 | 520 | 580 | 600 | 600 | 700 | 700 | 900 | 900 | 1000 | 1000 | 1200 | 1400 | 580 | 650 | 900 | 900 | 1400 | 700 | 900 | 1000 | 300 | 400 | 520 | 600 | 700 | 220 | 270 | 350 | 540 | 300 | 380 | 500 |
| | lbs | 726 | 968 | 1144 | 1276 | 1320 | 1320 | 1540 | 1540 | 1980 | 1980 | 2200 | 2200 | 2640 | 3080 | 1276 | 1430 | 1980 | 1980 | 3080 | 1540 | 1980 | 2200 | 660 | 880 | 1144 | 1320 | 1540 | 484 | 594 | 770 | 1188 | 660 | 836 | 1100 |
| Passengers capacity | | 2 | 3 | 4 | 4 | 5 | 5 | 6 | 6 | 8 | 8 | 9 | 9 | 10 | 12 | 4 | 5 | 6 | 6 | 12 | 7 | 9 | 10 | 2 | 3 | 4 | 4 | 5 | 2 | 3 | 3 | 4 | 2 | 3 | 4 |
| No of chambers **** | | 3 | 3 | 3 | 3 | 3 | 3 | 3 | 3 | 5 | 5 | 5 | 5 | 5 | 5 | 3 | 3 | 5 | 5 | 5 | 3+1 | 5+1 | 5+1 | 3+1/3+2 | 3+1/3+2 | 3+1/3+2 | 3+1/3+2 | 3+1/3+2 | 2 | 2/2+1 | 2/2+1 | 2/2+1 | 4+1 | 4+1 | 4+1 |
| Engine recommended | HP | 3 | 6 | 10 | 15 | 25 | 25 | 40 | 40 | 50 | 50 | 70 | 70 | 115 | 150 | 20 | 30 | 50 | 50 | 150 | 20 | 30 | 40 | 4 | 6 | 10 | 15 | 20 | 3 | 4 | 6 | 10 | 3 | 4 | 6 |
| | kW | 2,2 | 4,4 | 7,4 | 11 | 18,4 | 18,4 | 29,4 | 29,4 | 36,8 | 36,8 | 51,5 | 51,5 | 84,6 | 110,3 | 14,7 | 22,1 | 36,8 | 36,8 | 110,3 | 14,7 | 22,1 | 29,4 | 2,9 | 4,4 | 7,4 | 11 | 14,7 | 2,2 | 2,9 | 4,4 | 7,4 | 2,2 | 2,9 | 4,4 |
| Engine max | HP | 6 | 10 | 15 | 20 | 30 | 30 | 50 | 50 | 70 | 70 | 100 | 100 | 120 | 175 | 30 | 40 | 75 | 75 | 200 | 30 | 40 | 50 | 5 | 10 | 15 | 20 | 30 | 4 | 5 | 8 | 10 | 4 | 5 | 8 |
| | kW | 4,4 | 7,4 | 11 | 14,7 | 22,1 | 22,1 | 36,8 | 36,8 | 51,5 | 51,5 | 73,5 | 73,5 | 88,3 | 128,7 | 22,1 | 29,4 | 55,2 | 55,2 | 147,1 | 22,1 | 29,4 | 36,8 | 3,7 | 7,4 | 11 | 14,7 | 22,1 | 2,9 | 3,7 | 5,9 | 7,4 | 2,9 | 3,7 | 5,9 |
| Engine weight max | kg | 35 | 45 | 50 | 60 | 80 | 80 | 115 | 115 | 150 | 150 | 175 | 175 | 240 | 300 | 70 | 95 | 175 | 175 | 300 | 80 | 95 | 115 | 25 | 45 | 50 | 50 | 80 | 25 | 30 | 40 | 45 | 25 | 30 | 40 |
| | lbs | 77 | 99 | 110 | 132 | 176 | 176 | 253 | 253 | 330 | 330 | 386 | 386 | 528 | 660 | 154 | 209 | 385 | 385 | 660 | 176 | 209 | 253 | 55 | 99 | 110 | 110 | 176 | 55 | 66 | 88 | 99 | 55 | 66 | 88 |
| Engine shaft length | inches | 15"(short) | 15"(short) | 15"(short) | 15"(short) | 15"(short) | 15"(short) | 20"(15" opt) | 20"(15" opt) | 20"(long) | 20"(long) | 20"(long) | 20"(long) | 20"(long) | 20"(long) | 15"(short) | 20"(long) | 20"(long) | 20"(long) | 20"(long) | 15"(short) | 20"(long) | 20"(long) | 15"(short) | 15"(short) | 15"(short) | 15"(short) | 15"(short) | 15"(short) | 15"(short) | 15"(short) | 15"(short) | 15"(short) | 15"(short) | 15"(short) |
| Midsection / aft deadrise | degrees | 17° / 15° | 17° / 15° | 19° / 15° | 19° / 15° | 20° / 17° | 20° / 17° | 20° / 17° | 20° / 17° | 20° / 15° | 20° / 15° | 20° / 15° | 20° / 15° | 23° / 18° | 22° / 18° | 17° / 14° | 17° / 15° | 20° / 17° | 20° / 17° | 25° / 20° | 15° / 12° | 17° / 13° | 17° / 13° | 11° / 8° | 10° / 7° | 10° / 7° | 10° / 7° | 12° / 8° | 0° | 0° / 5°-12° | 0° / 5°-12° | 0° / 5°-12° | 0° | 0° | 0° |
| Stowed dimensions | cm | 208 | 225 | 253 | 265 | 305 | 305 | 350 | 350 | 400 | 400 | 450 | 450 | 530 | 610 | 320 | 350 | 433 | 433 | 640 | 135 | 165 | 165 | 115 | 115 | 115 | 115 | 135 | 100 | 100 | 115 | 115 | 95 | 95 | 95 |
| | cm | 114 | 114 | 115 | 115 | 153 | 153 | 145 | 145 | 170 | 170 | 170 | 170 | 210 | 220 | 140 | 158 | 166 | 166 | 230 | 67 | 70 | 80 | 60 | 60 | 60 | 67 | 56 | 56 | 60 | 60 | 65 | 65 | 65 | |
| | cm | 46 | 46 | 57 | 57 | 71 | 71 | 77 | 77 | 78 | 78 | 70 | 70 | 118 | 120 | 82 | 88 | 94 | 94 | 140 | 40 | 36 | 38 | 32 | 32 | 32 | 32 | 40 | 30 | 30 | 32 | 32 | 35 | 45 | 55 |
| of package No 1 | ft/inches | 6' 10" | 7' 5" | 8' 4" | 8' 8" | 10' 0" | 10' 0" | 11' 5" | 11' 5" | 13' 1" | 13' 1" | 14' 9" | 14' 9" | 17' 5" | 20" | 10' 6" | 11' 6" | 14' 2" | 14' 2" | 21' 0" | 4' 5" | 5' 5" | 5' 5" | 3' 9" | 3' 9" | 3' 9" | 3' 9" | 4' 5" | 3' 3" | 3' 3" | 3' 9" | 3' 9" | 2' 11" | 2' 11" | 2' 11" |
| | ft/inches | 3' 9" | 3' 9" | 3' 9" | 3' 9" | 5' 0" | 5' 0" | 4' 9" | 4' 9" | 5' 7" | 5' 7" | 5' 7" | 5' 7" | 6' 11" | 7' 3" | 4' 7" | 5' 2" | 5' 5" | 5' 5" | 7' 7" | 2' 2" | 2' 4" | 2' 7" | 2' 0" | 2' 0" | 2' 0" | 2' 2" | 1' 10" | 1' 10" | 2' 0" | 2' 0" | 2' 2" | 2' 2" | 2' 2" | |
| | ft/inches | 1' 6" | 1' 6" | 1' 10" | 1' 10" | 2' 4" | 2' 4" | 2' 6" | 2' 6" | 2' 7" | 2' 7" | 2' 4" | 2' 4" | 3' 10" | 3' 11" | 2' 8" | 2' 11" | 3' 1" | 3' 1" | 4' 7" | 1' 4" | 1' 2" | 1' 3" | 1' 1" | 1' 1" | 1' 1" | 1' 4" | 1' 0" | 1' 0" | 1' 1" | 1' 1" | 1' 2" | 1' 6" | 1' 10" | |
| Stowed dimensions | cm | | | /130 | /130 | /130 | 83 | /155 | 83 | /155 | 94 | /155 | 108 | 122 | 127 | 49 | 83 | 65 | 65 | 127 | 109 | 133 | 170 | | | | 110 | 110 | 120 | | | | | | |
| | cm | | | /70 | /70 | /70 | 86 | /90 | 86 | /90 | 73 | /90 | 114 | 110 | 121 | 49 | 51 | 60 | 60 | 121 | 62 | 78 | 78 | | | | 60 | 60 | 65 | | | | | | |
| | cm | | | /43 | /43 | /43 | 51 | /51 | 51 | /51 | 54 | /51 | 72 | 90 | 110 | 80 | 86 | 60 | 60 | 110 | 16 | 24 | 22 | | | | | | | | | | | | |

ACCESSORIES & OPTIONAL EQUIPMENT



Steering console CL-01
Main dimensions:
L580 x B480 x H960 (23' x 19' x 38')



Steering console CL-02
Main dimensions:
L825 x B480 x H1120 (23' x 19' x 38')



Steering console CL-03
Main dimensions:
L1100 x B620 x H1200 (43' x 24' x 47')



Steering console CL-04, CL-05
Main dimensions:
CL-04: L1125 x B1040 x H1680 (45' x 42' x 67')
CL-05: L960 x B900 x 1460 (38' x 36' x 58')



CL-04

Cruising bar SD-04
Main dimensions:
L825 x B1060 x H925 (33' x 44' x 37')



Steering console CS-01
Main dimensions:
L1300 x B400 x H675 (23' x 19' x 38')



Double seats SD-01,SD-02,SD-03
Main dimensions:
L550 x B1050 x H960 (22' x 43' x 33')
L550 x B1150 x H960 (22' x 45' x 33')
L650 x B1250 x H1060 (25' x 50' x 36')



Standing bar SD-05
Main dimensions:
L550 x B1050 x H960 (22' x 43' x 33')



Keel and tube protection system
Please specify the boat model and package type when ordering.



Package A
(Keel line only)

Package B
(Tube on both sides)

Steering console CS-02
item #2210



Steering console cover
Please specify the console model when ordering



Stainless steel railing for consoles
CL-01, CL-02 – item #2250, CL-03 – item #2251



3-arch collapsible suntop
Please specify the boat model when ordering.



Boat Cleaning and Maintenance kit



This kit includes:
1. SPEED CLEAN – unique active cleaner with HYPEXINE™, especially designed for PVC and HYPALON inflatable boats.
2. POLYGUARD – a new Space Age polymer for complete protection of your boat against environment, gas, dirt, UV, stains etc. It does NOT contain silicon or wax!!!
Regular use of them will assure extended lifetime and perfect shape of your boat.
These products, manufactured by AURORA, Canada, are only chemicals, officially approved by GMG for GRAND inflatable boats!

Seat cushion with under-seat bag
Please specify the boat model when ordering



Boat overall cover
Please specify the boat model when ordering



ATTENTION! All the consoles standard sets do NOT include any controls, instruments and steering. They should be ordered separately!

WELCOME TO THE OFFICIAL WEB SITE OF GRAND MARINE GROUP

www.grandboats.com



GRAND MARINE INTERNATIONAL INC.
14 Connie Cres., Unit 14, Concord, ON, L4K2W8, Canada
Tel: 1-905-7608519, Fax: 1-905-7608719,
E-mail: mail@grandboats.com

GRAND INTERNATIONAL DISTRIBUTION NETWORK

| | | | | | |
|--|--|--|--|---|---|
| CANADA GRAND MARINE CANADA 14 Connie Crescent, Unit 14 Concord, Ontario, L4K 2W8, Canada Tel: +1 905 760 8519 E-mail: mail@grandboats.com | ESTONIA BALTIC SEAL OU PUNANE 6 (stock 16), Tallin, 13619, Estonia Tel: +372 53 408 542 E-mail: ri@balticseal.ee | GREECE LEADMAR Ltd 31 Vouliagmenis Avenue, Glyfada, 16675, Athens, Greece Tel: +30 210 9700 200 E-mail: info@leadmar.gr | THE NETHERLANDS RUBBERBOOT BENELUX Blankenburg 11, Westzaan, 1551 AS, The Netherlands Tel: +31 75 614 5379 E-mail: info@grandboats.nl | KALININGRAD REG.(RUSSIA) LAGUNA Ul. Professora Baranova 2, Pav 18, Kaliningrad, 236000, Russia Tel: +7 4012 761 441 E-mail: pnv57e@mail.ru | TURKEY SELIM BERGSEN Levent Mahallesi Al Karanfil Sokak No: 3 Besiktas - Istanbul, 34330 Turkey Tel: +90 212 270 70 64 E-mail: info@bergboat.com |
| AUSTRALIA IMIX Pty Ltd 3333 Pacific Highway, Springwood, Queensland, QLD 4127, Australia Tel: +61 7 3209 2977 E-mail: tbc@iboat.com.au | FINLAND Mc SEA OY Martinsillantie 24, 02300, Espoo, Finland Tel: +358 9 809 4446 E-mail: mcsea@mcsea.fi | LATVIA RADOX GROUP LTD 240, Maskavas str, Riga, LV-1063, Latvia Tel: +371-67-144689 E-mail: info@grandboats.lv | NORWAY SWEDEN GOVI AS RB. 1065 - Lundsiden N-4687 Kristiansand, Norway Tel: +47 380 15400 E-mail: terje@govi.no | SLOVENIA CROATIA MOTO-NAUTIKA Ptujška cesta 63, 2204 Miklavž pri Mariboru, Slovenia Tel: +386 2629 0400 E-mail: info@moto-nautika.com | UNITED KINGDOM WILLS MARINE Ltd. The Quay, Kingsbridge, South Devon, TQ7 1JF, UK Tel: +44 1548 852424 E-mail: info@willsmarine.co.uk |
| CZECH REP. SLOVAKIA AVAR-YACHT s.r.o. Za Rekou 815, Veverska Bityska, Brno-venkov, 66471, Czech Rep. Tel: +420 546 428 015 E-mail: yacht@avaryacht.cz | GERMANY AUSTRIA SWITZERLAND NAUTIKPRO GmbH Am Sandzug 6, D-67122 Altrip, Germany Tel: +49 6236 399551 E-mail: post@nautikpro.de | LIBYA FULK Al Hawari Alnihar St. Benghazi Libya Tel: +218 92 511 2391 E-mail: sami@fulk-libya.com | RUSSIA GRAND MARINE Ul 3-go Internatsionala 23, office 2 Belgorod 308001 Russia Tel: +7 905 6774440 E-mail: grand.marine@mail.ru | HUNGARY HANEX Levelezési cím, 1213 Budapest Hungary Tel: +36 30 9407 734 E-mail: grand@grandboats.net | UKRAINE GRAND MARINE Selyanskaya 124, Kharkov, 61157 Ukraine Tel: +380 57 7840125 E-mail: mail@grandmarine.com.ua |