



IPLA

GÉPTERVEZÉS ÉS GYÁRTÁS



**AHOL A MINŐSÉG ÉS PRECIZITÁS
ALAKOT ÖLT...**

TERVEZÉS

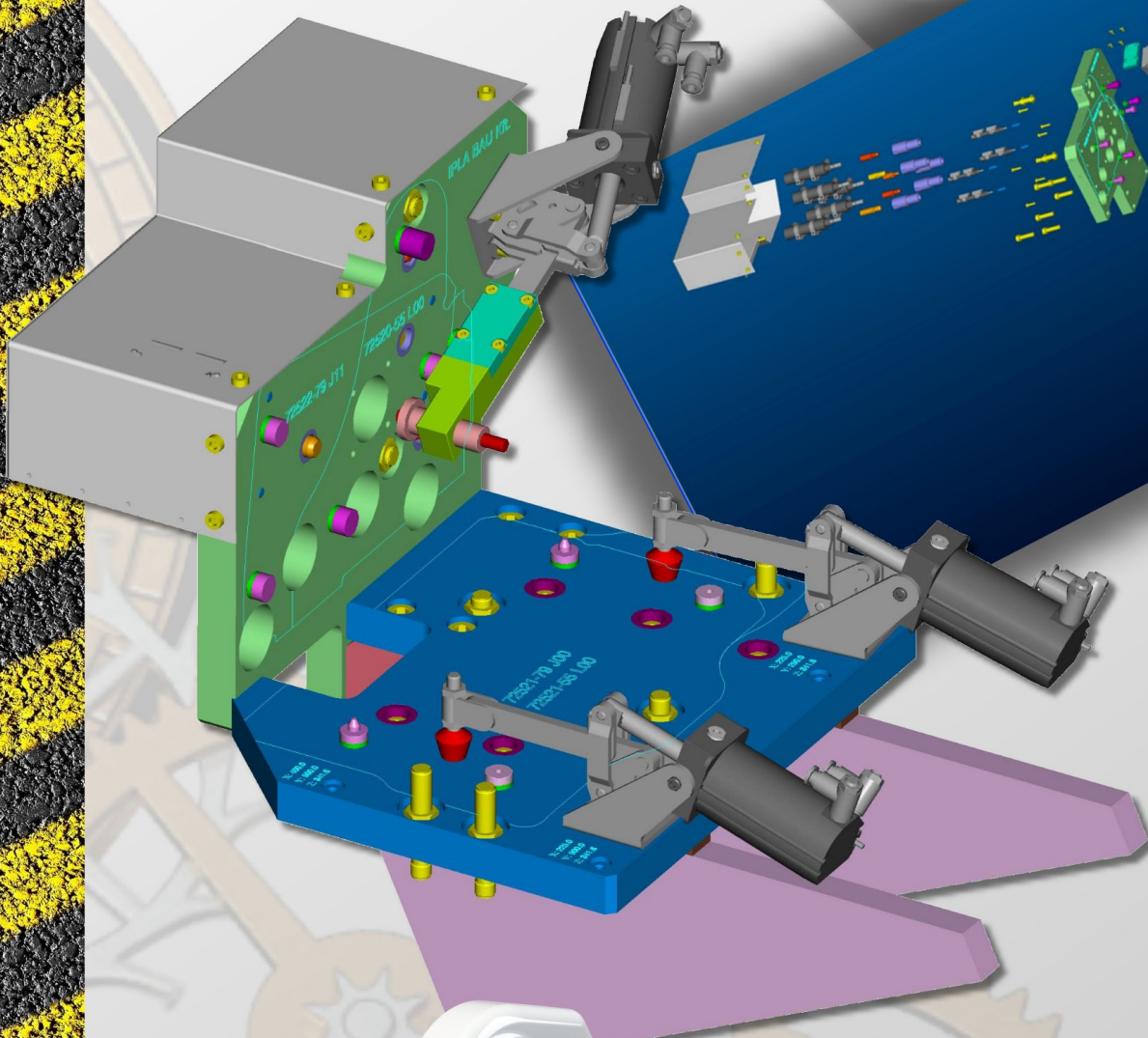

Powered by

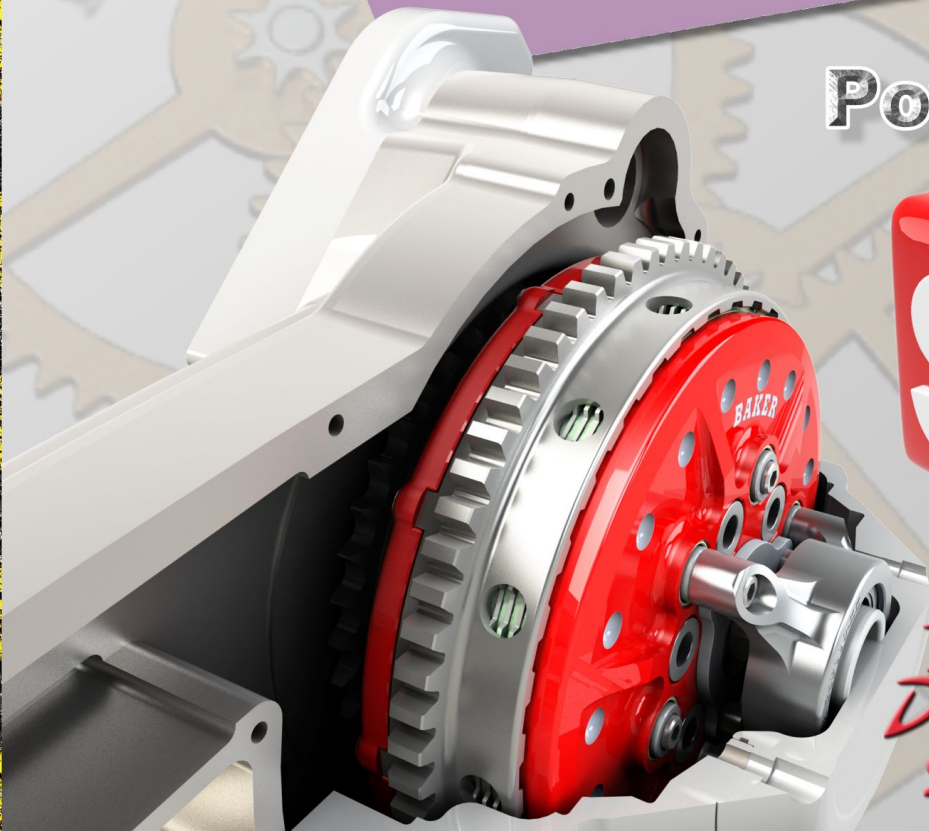

3S

SOLIDWORKS





**Naprakész
mérnökökkel,
a legmodernebb
megoldásokkal.
Önért!**

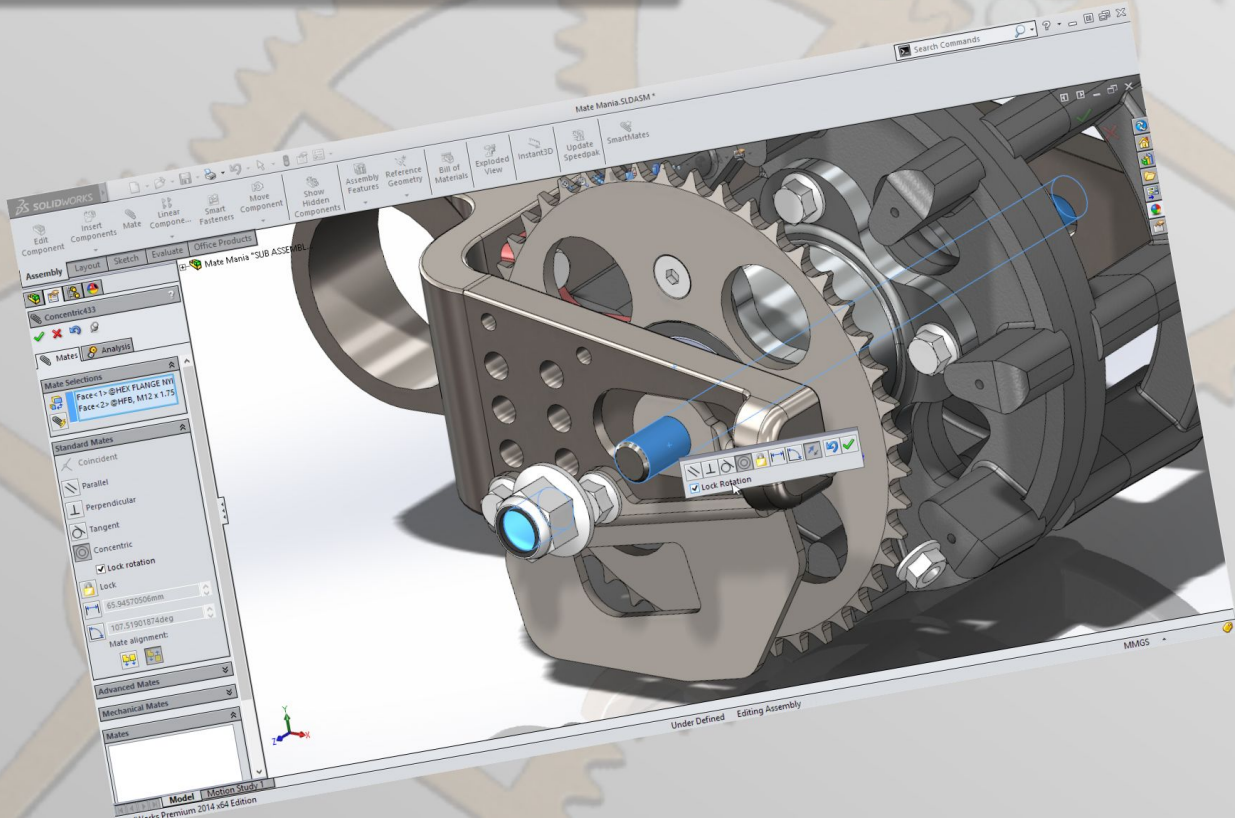
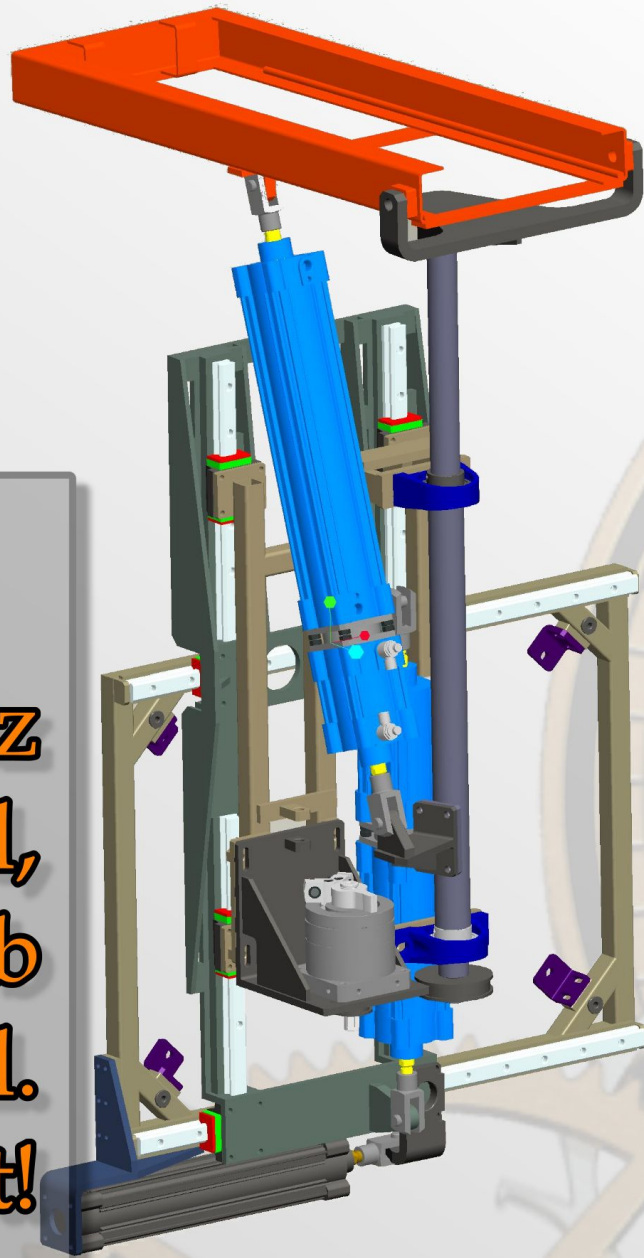

3D MÉRÉS-Scan



Szkennelt alkatrész

Rajzolt Cad modell

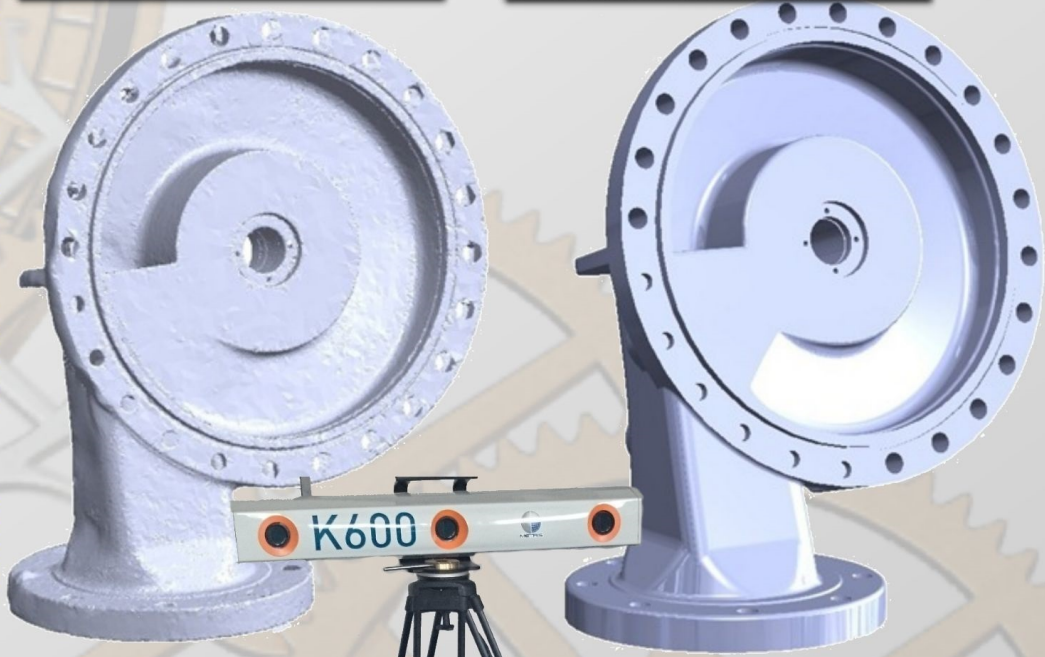

Prototípus

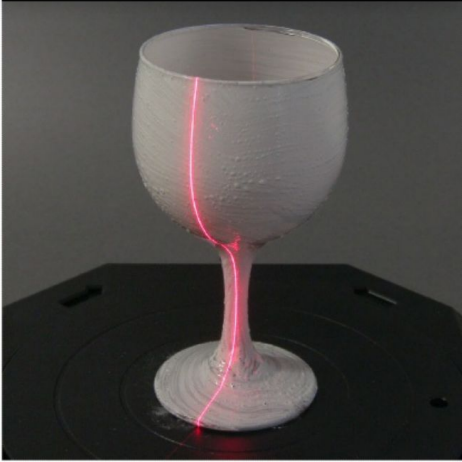

Digitális modell

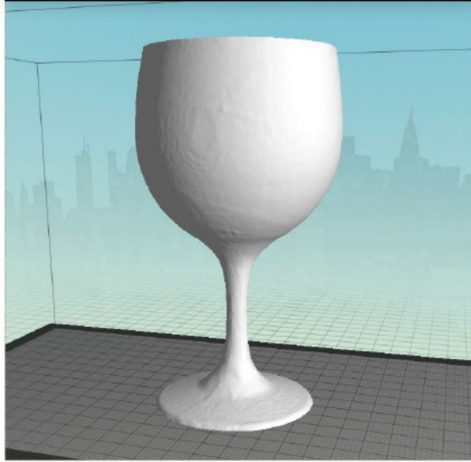

**A 3D-s szkennelés
korlátlan lehetőség a forma
digitális térbe juttatásához.**

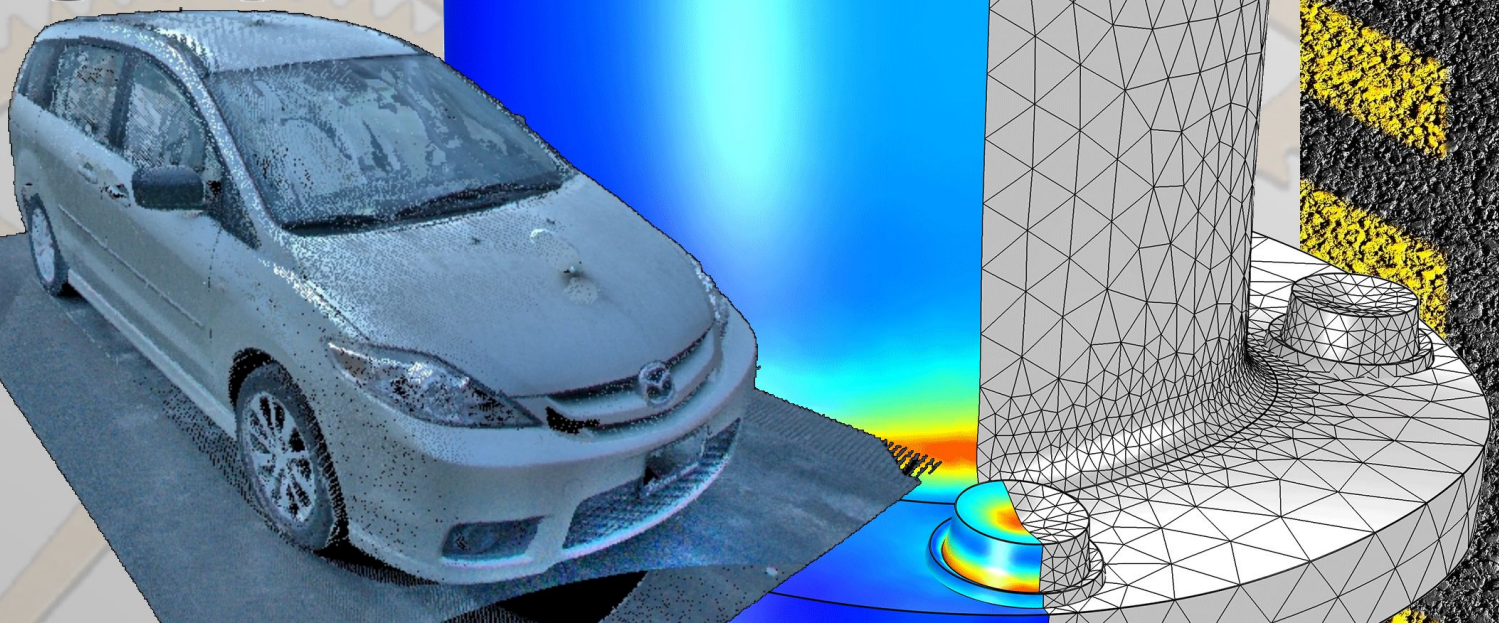

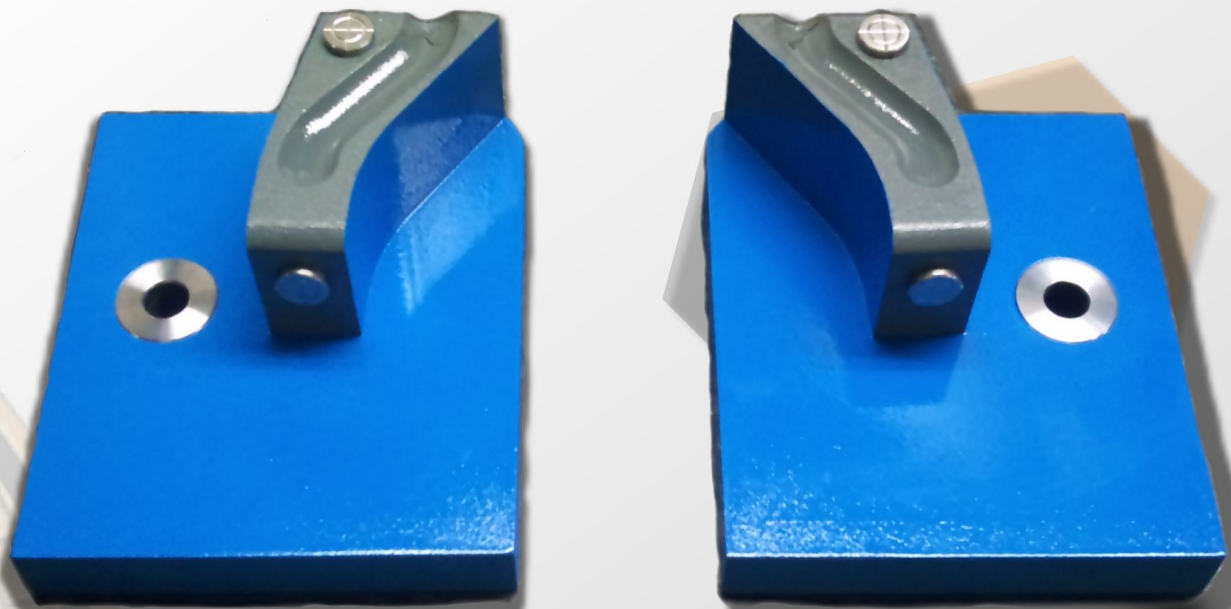

CHECKER

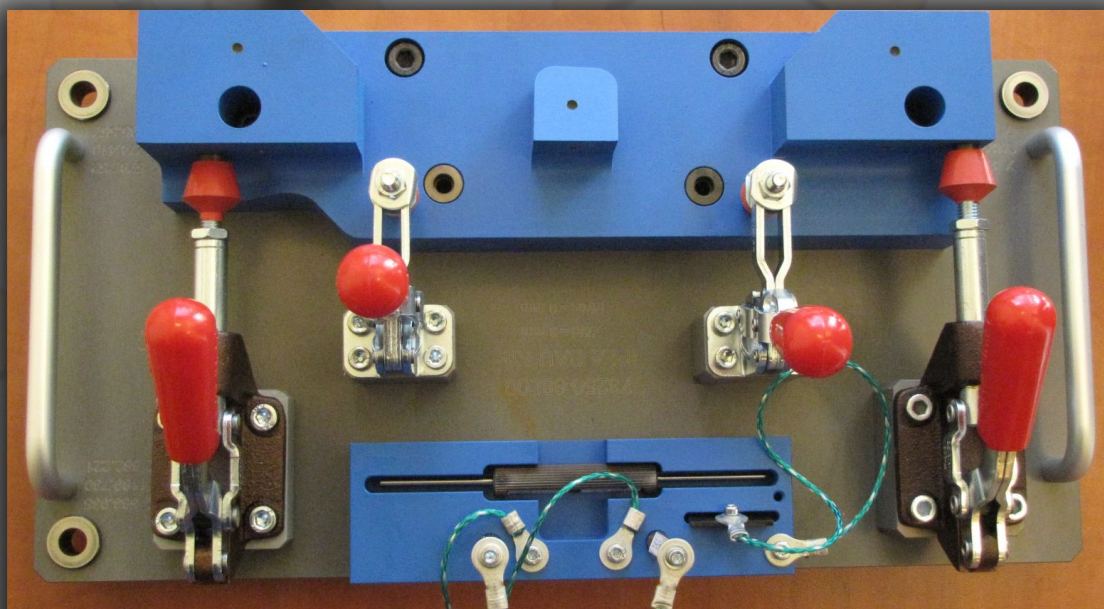
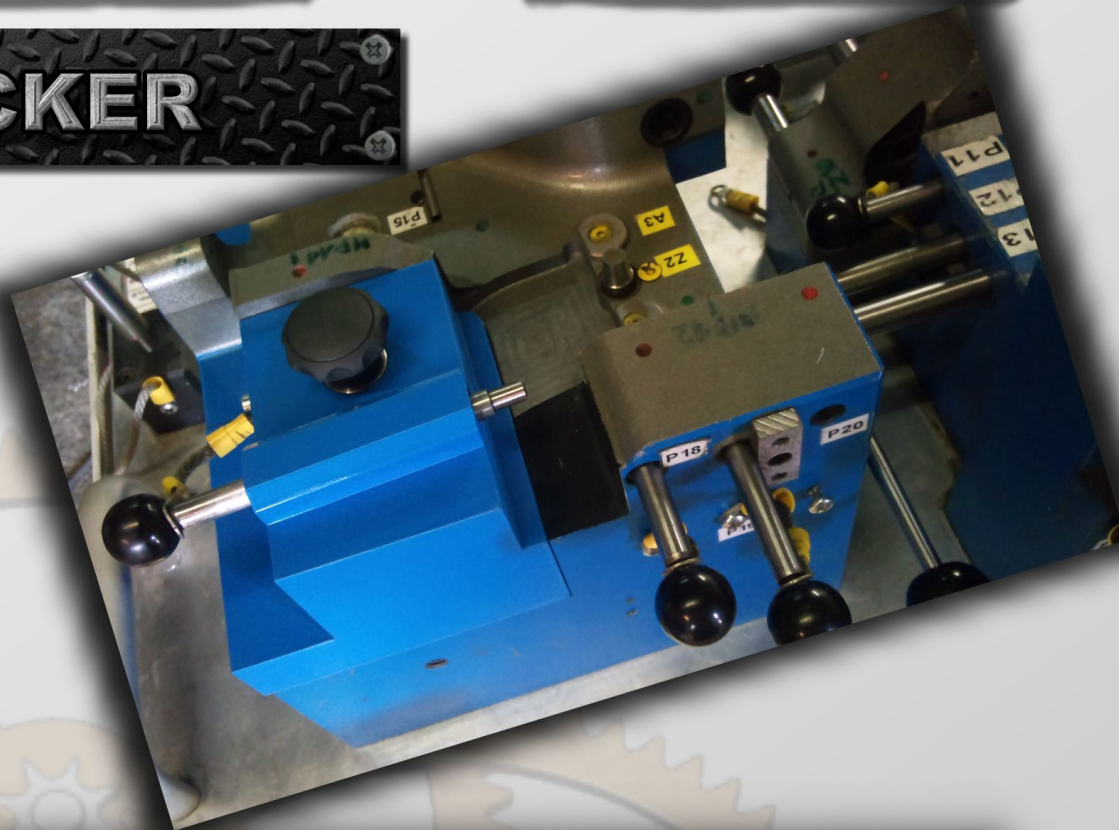

Mérő - ellenőrző készülékek



CÉLGÉPEK

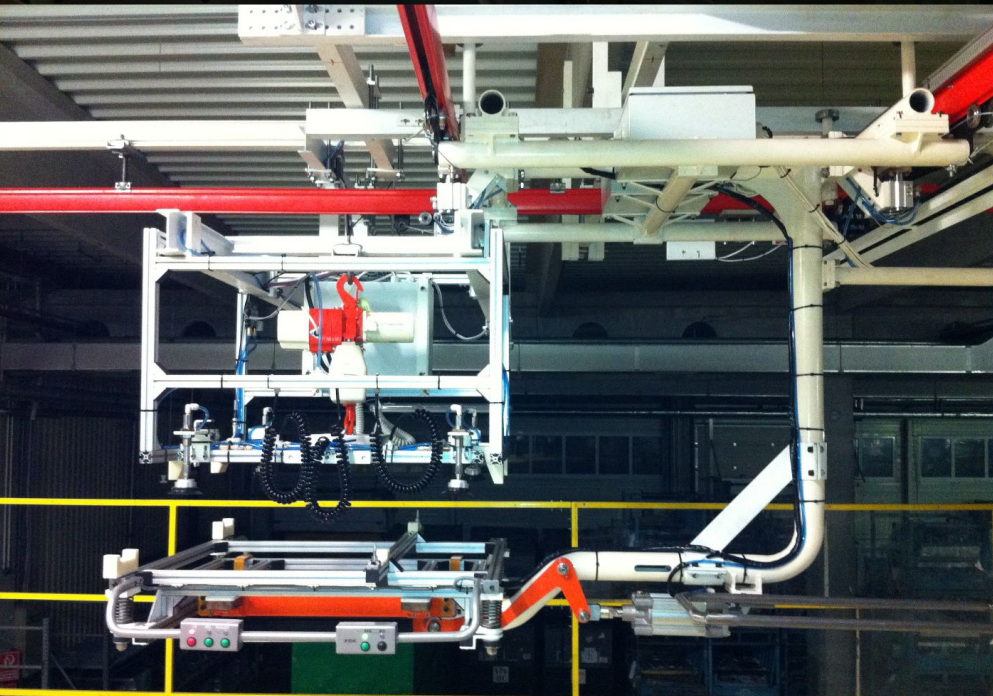

Manipulátorok



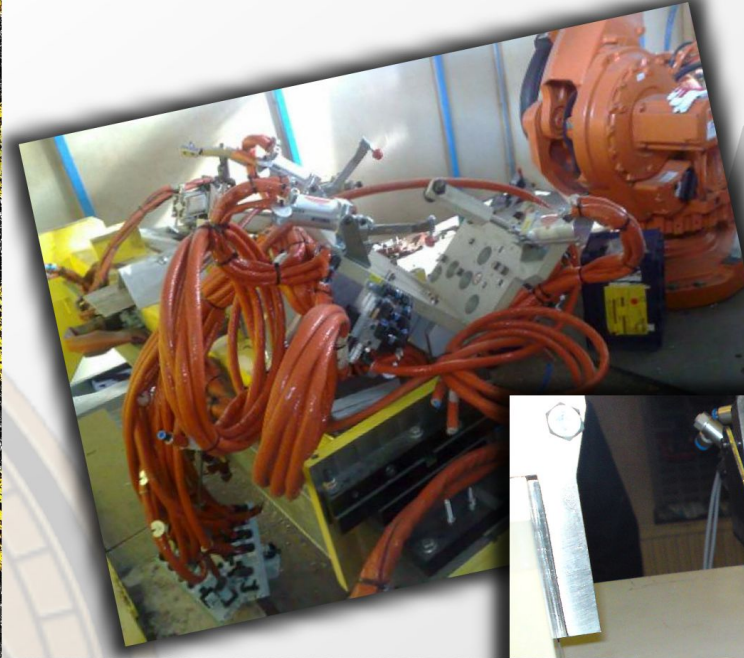

CÉLGÉPEK

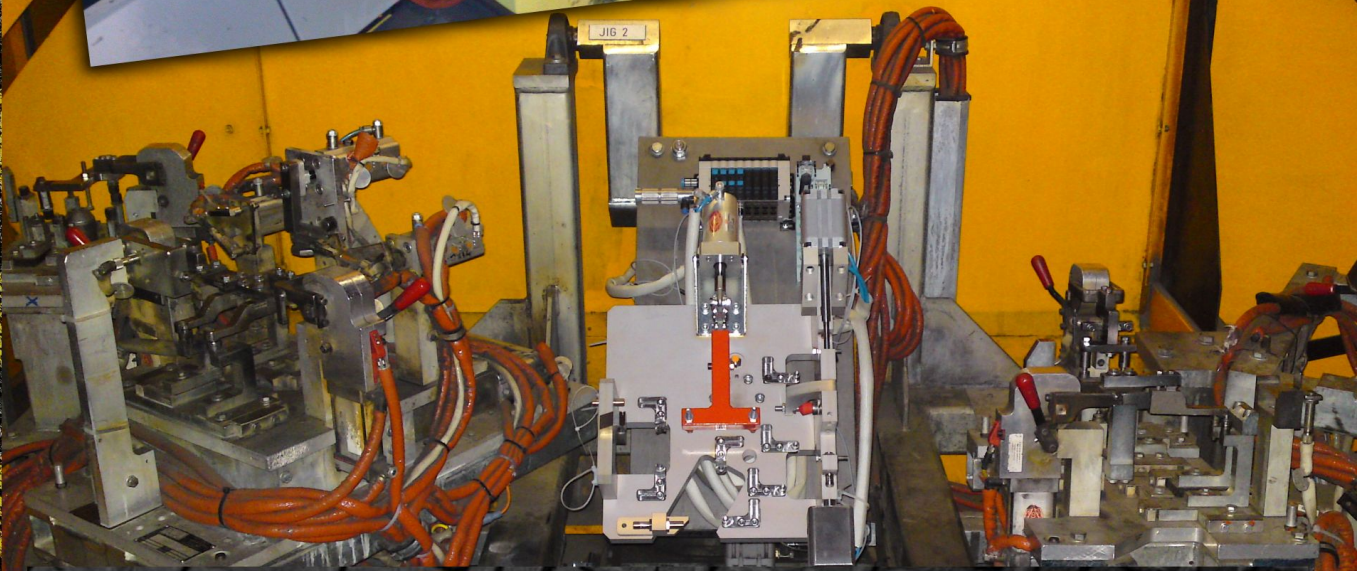
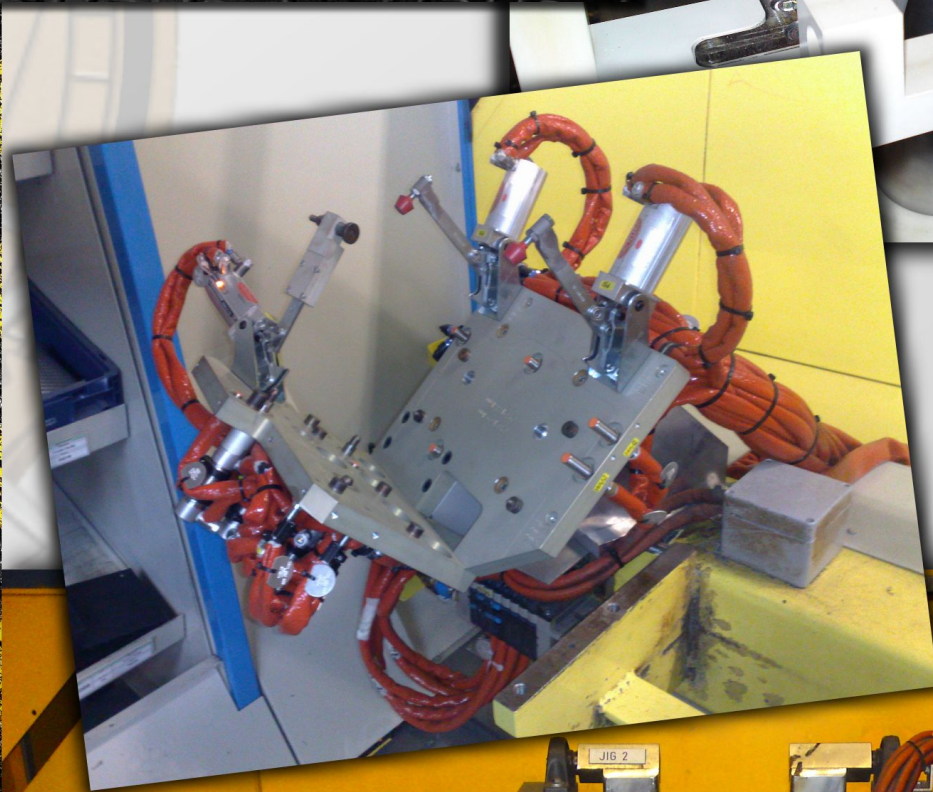

Hegesztő-tájéoló készülékek

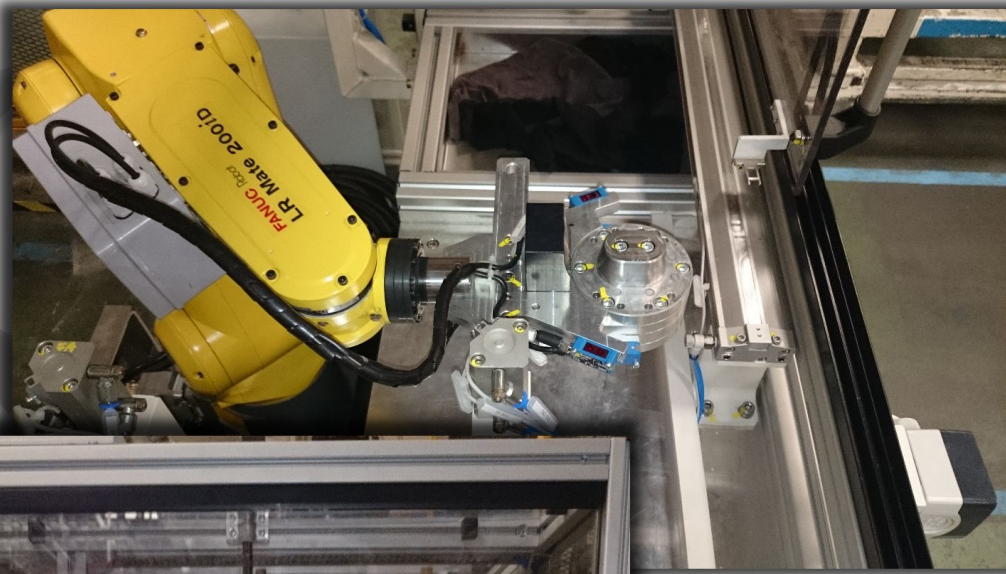

CÉLGÉPEK

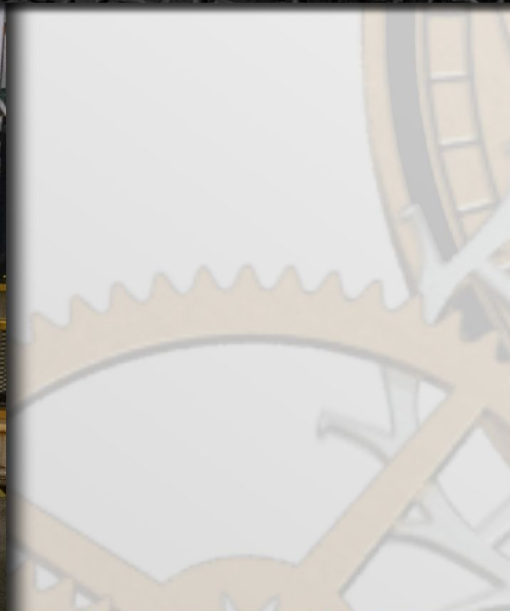

Robotos Sealer gép



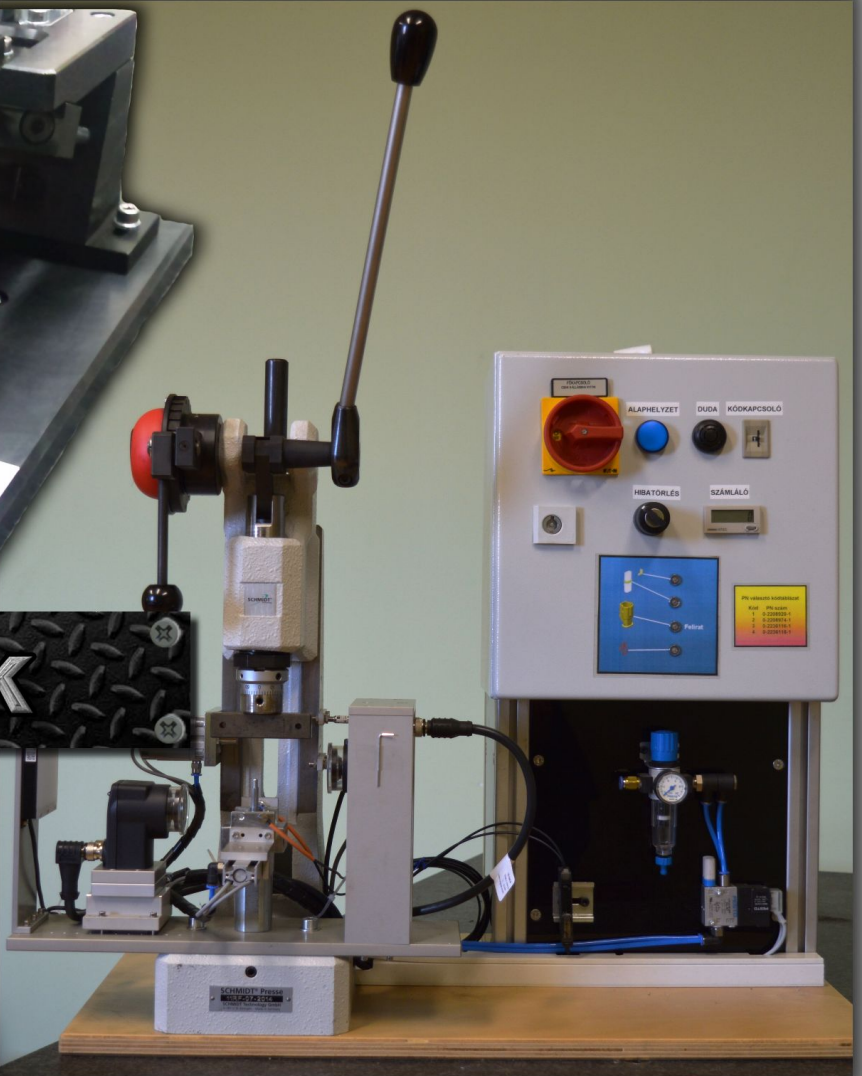
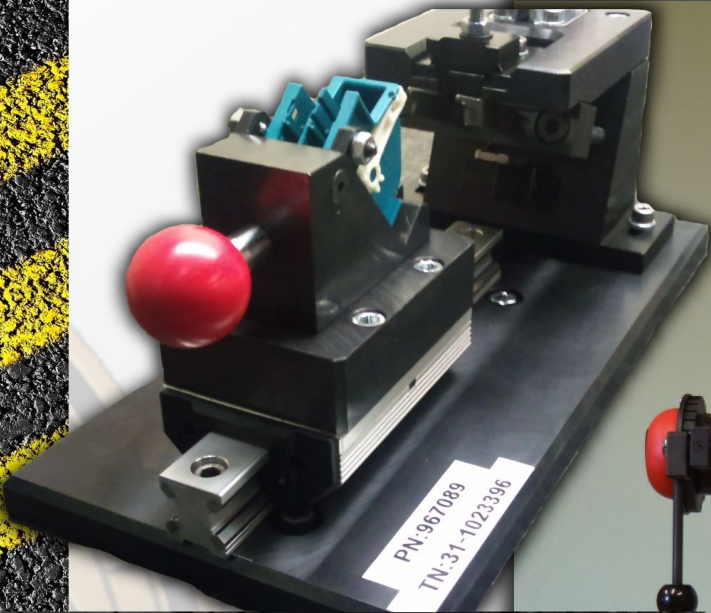

CÉLGÉPEK

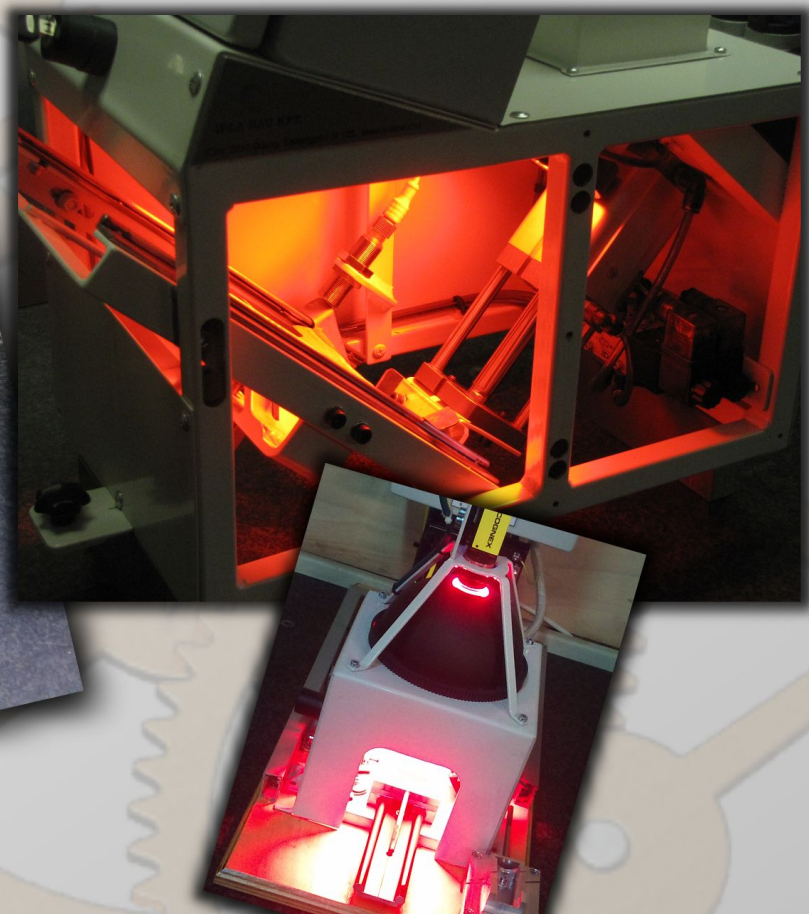
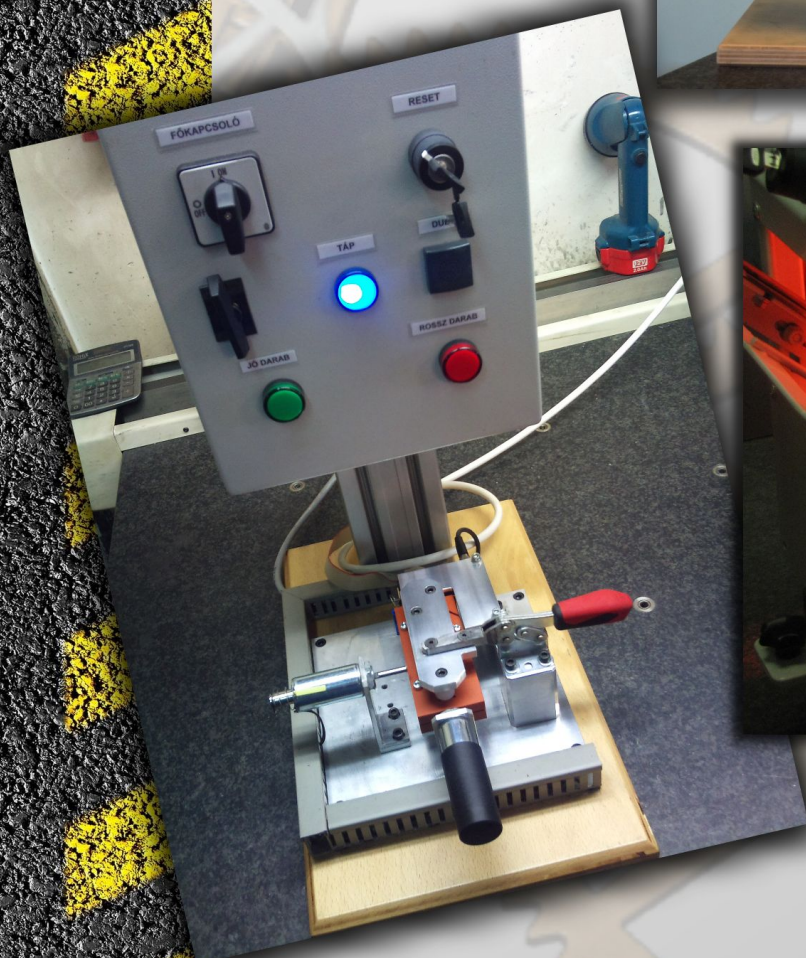

Szerelő - tesztelő eszközök



CÉLGÉPEK

Szerelő - tesztelő eszközök



ACÉL SZERKEZET





ACÉL SZERKEZET



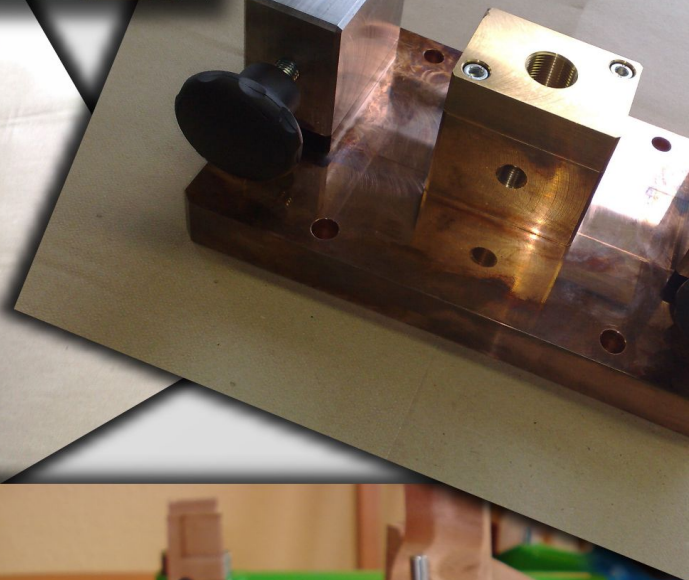

Kötőelem Hegesztés

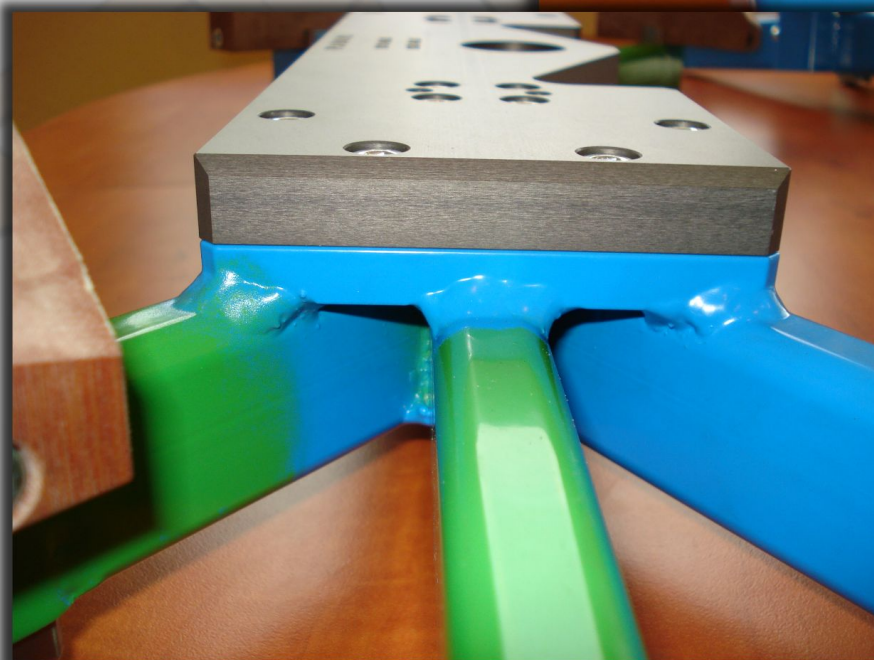
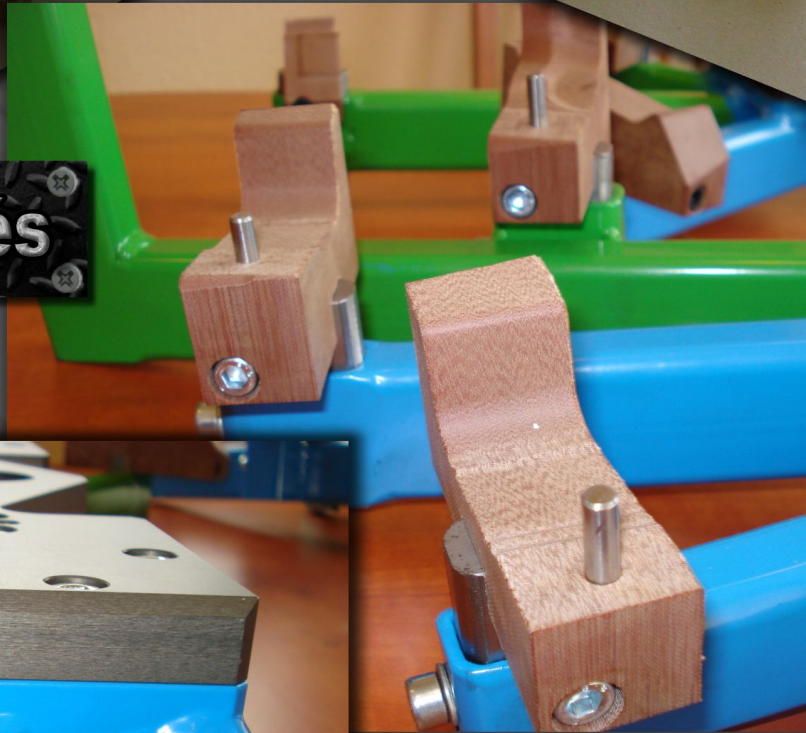

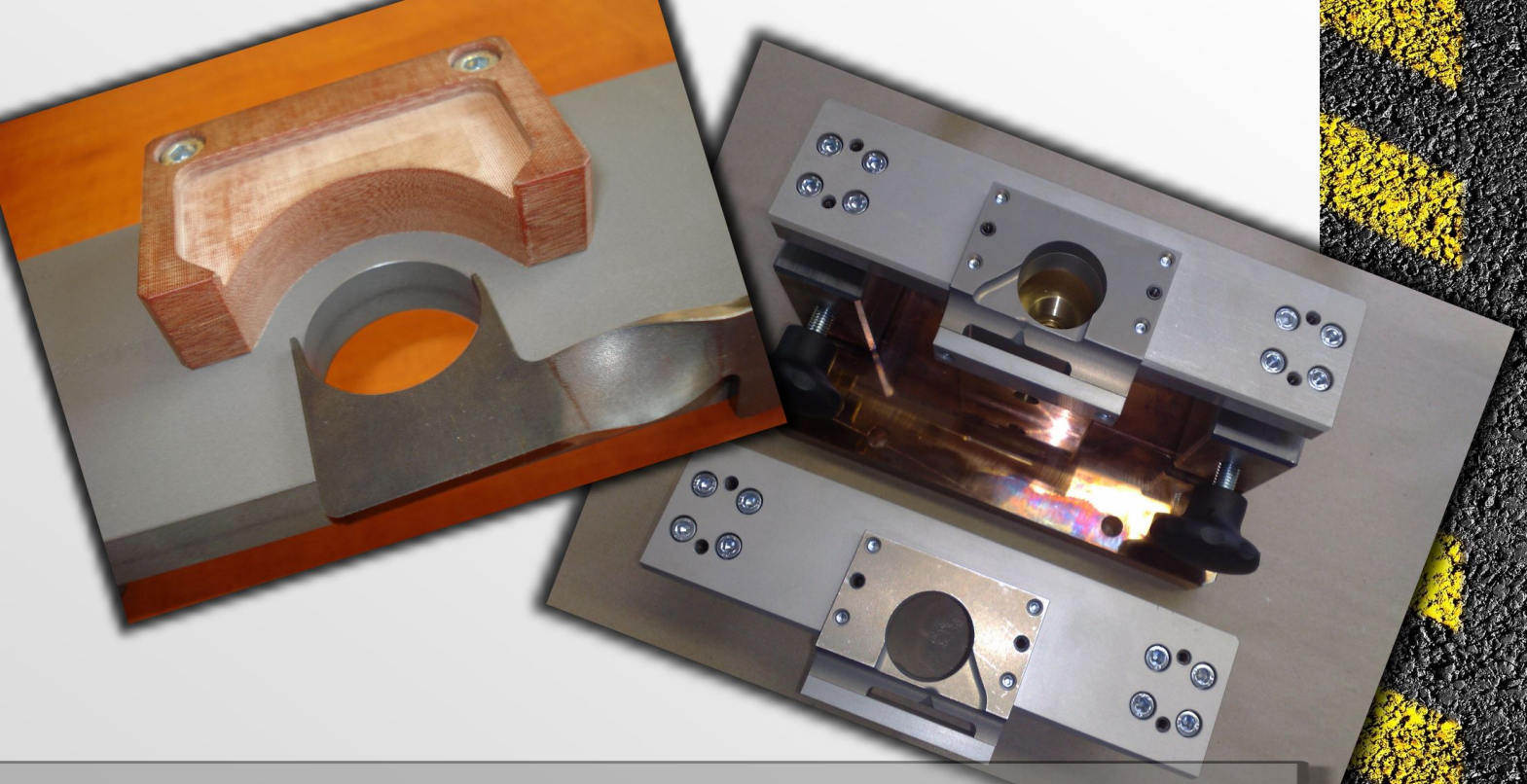

**Pont-, anya és csavar hegesztés
automata adagolóval a
hatékonyság és biztonság érdekében.**

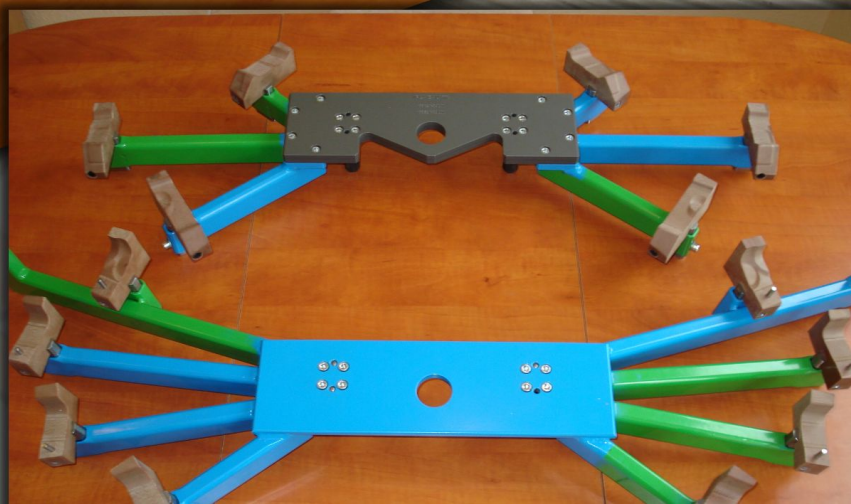
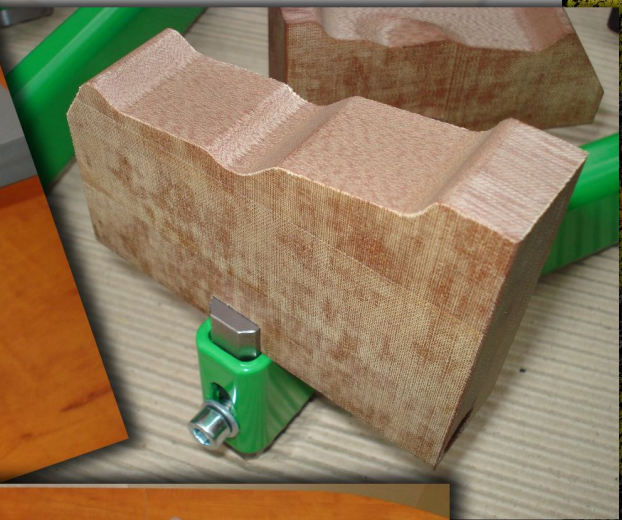

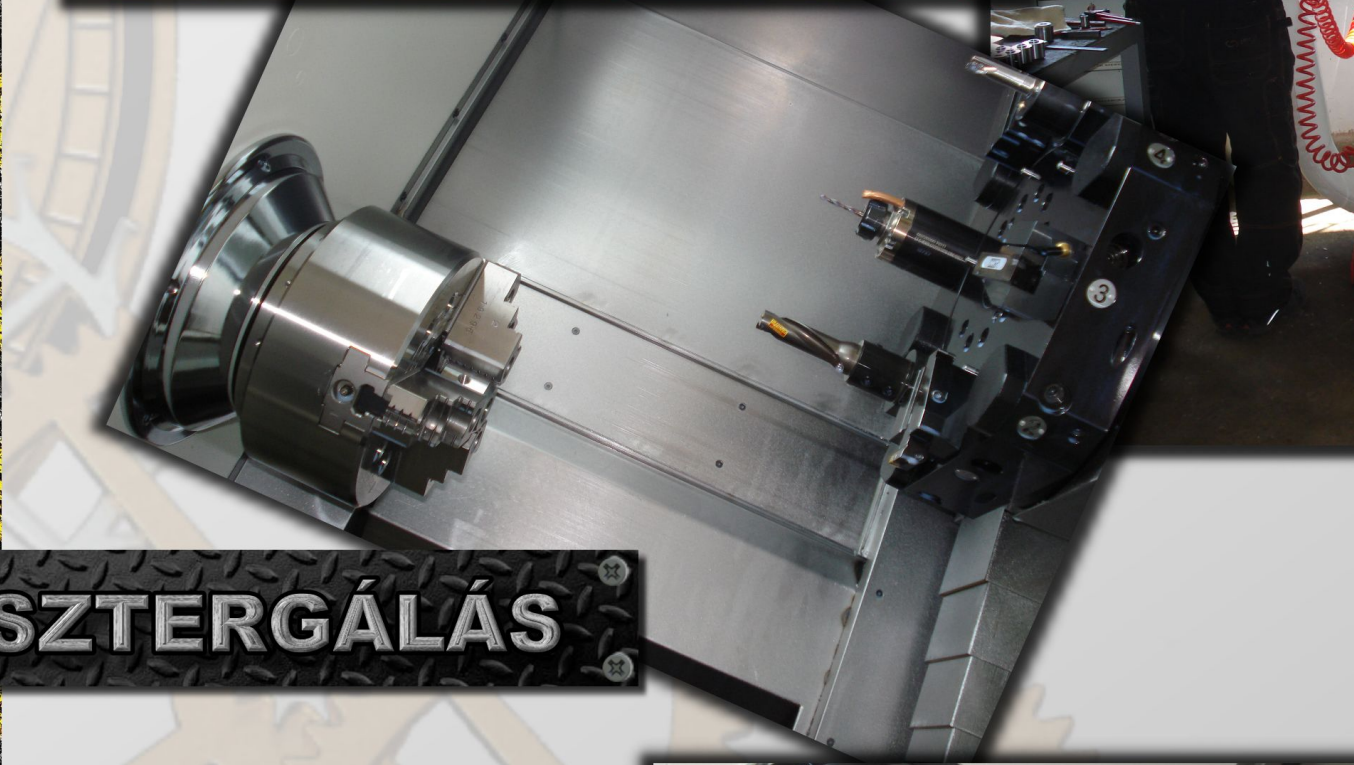
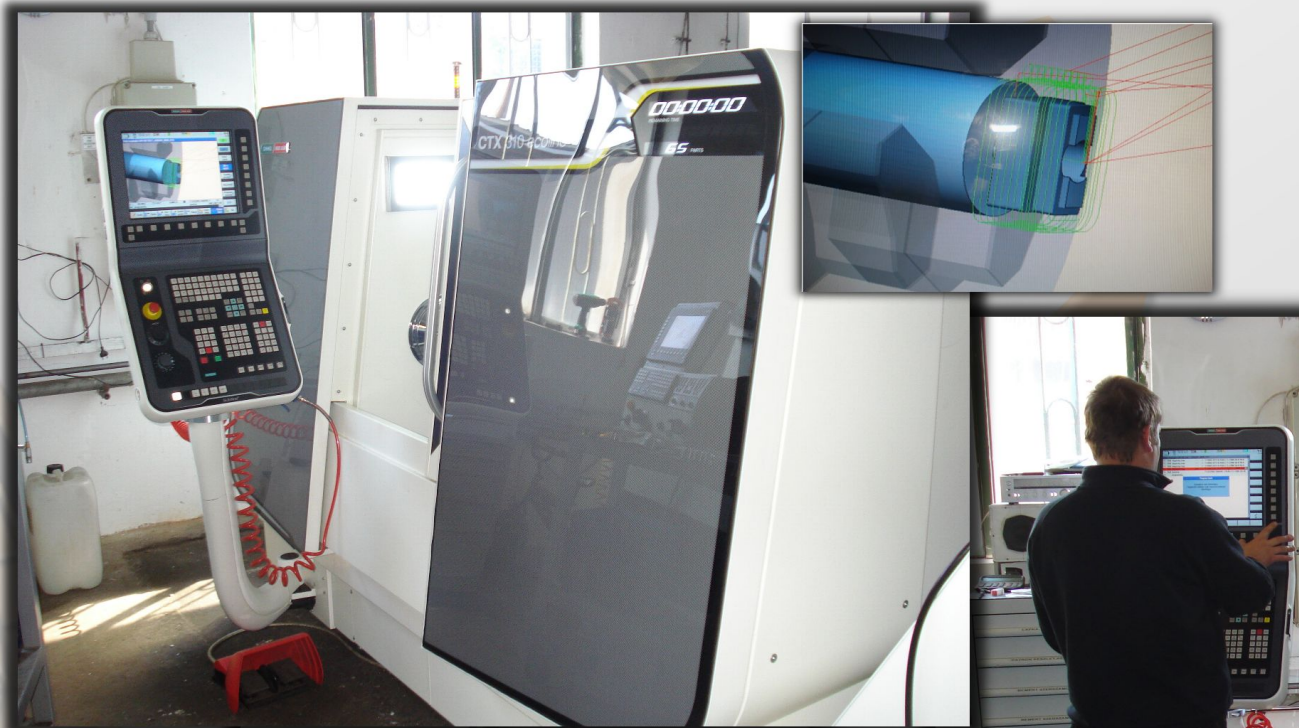

ESZTERGÁLÁS

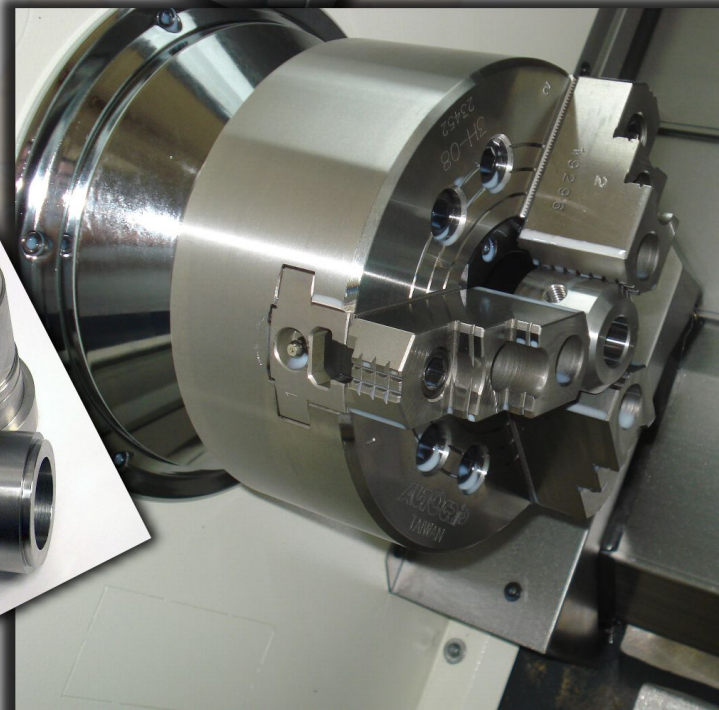

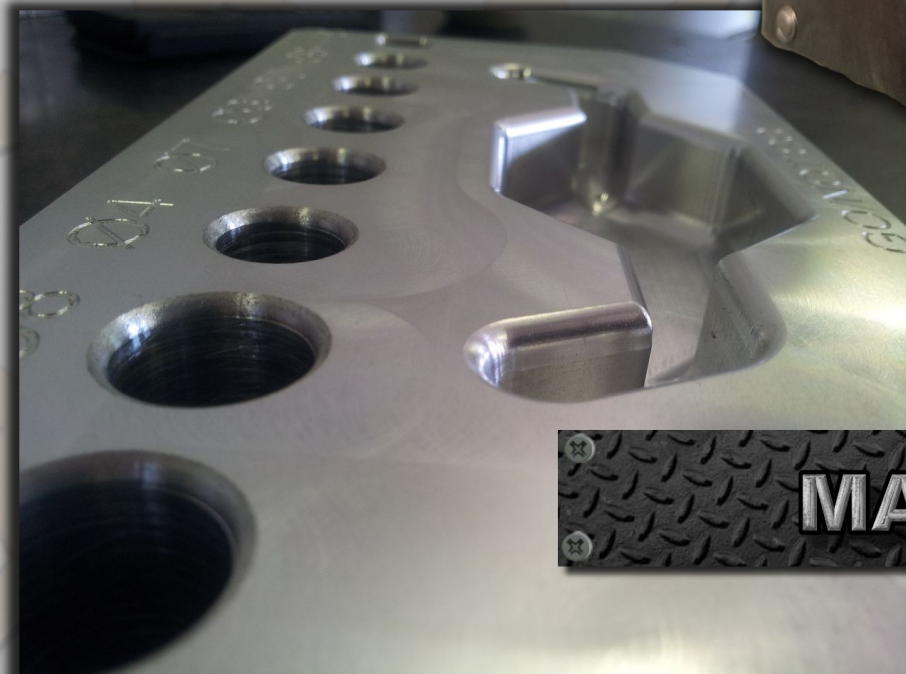
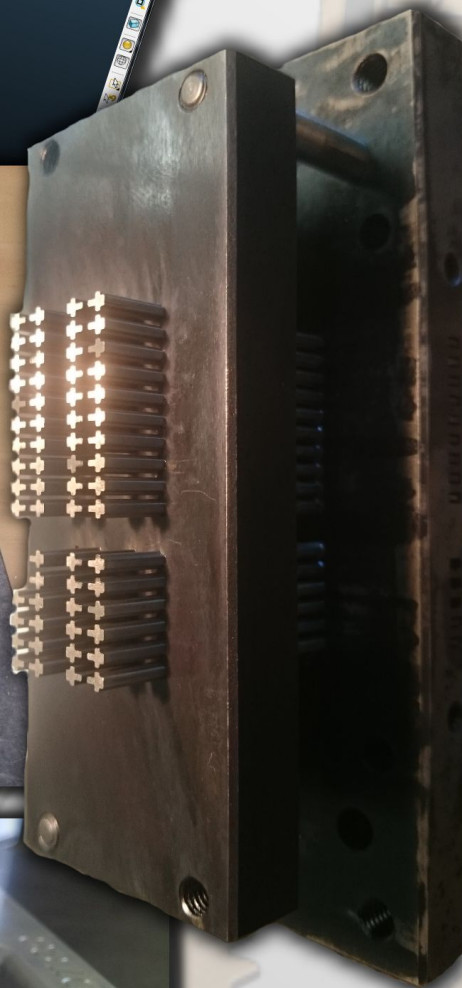
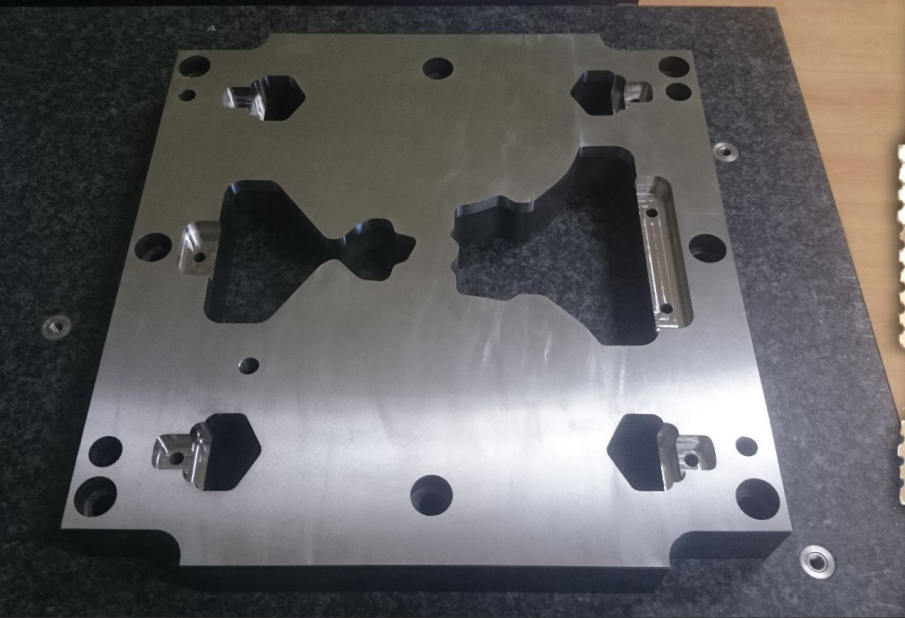
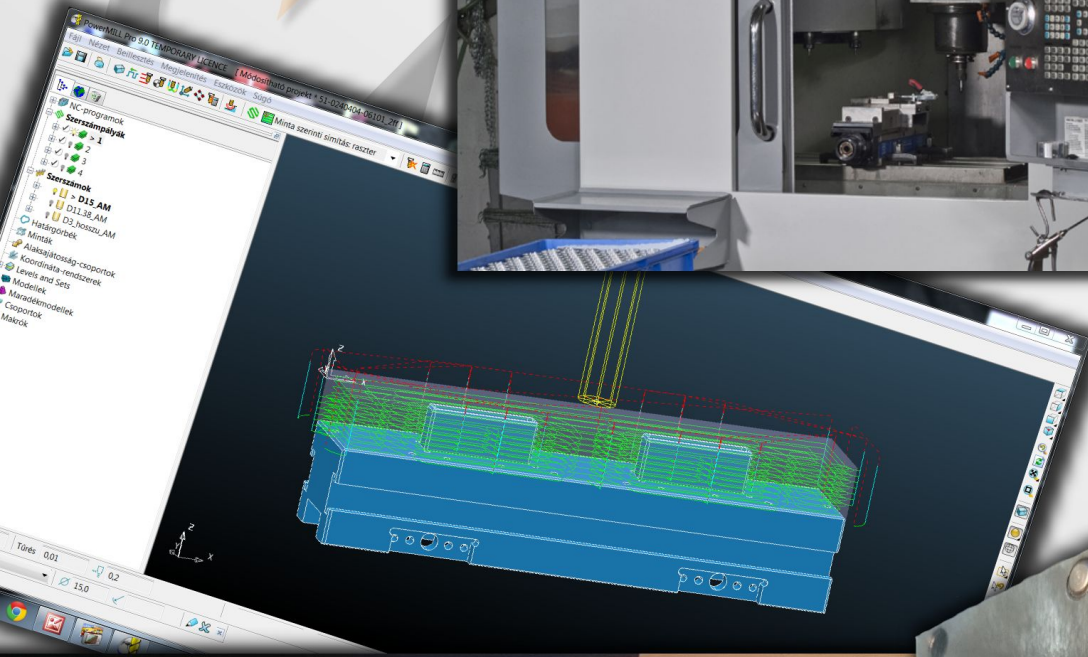
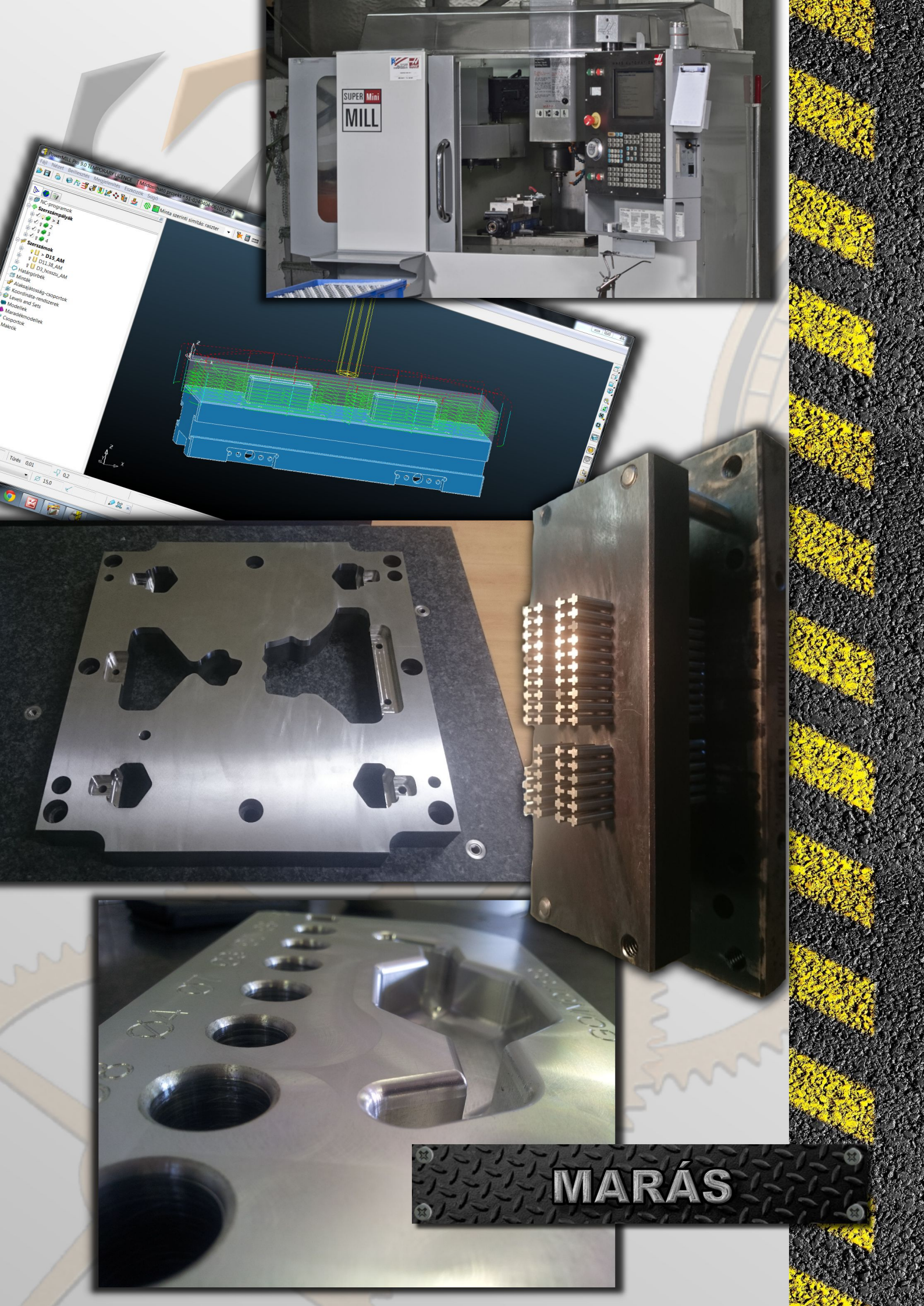

MARÁS



GYÁRTMÁNYOK



**Egyedi , kis-, közép és nagy szériás gyártás,
az Ön igényeihez igazítva.
Megbízhatóság, pontosság, rugalmasság...**





IPLA

GÉPTERVEZÉS ÉS GYÁRTÁS

IPLA KFT

2531 Tokod, Hrsz. 025/6

Géptervezés - Gépgyártás - Forgácsolás - Lakatos munkák - Vezérléstechnika
Alkatrész ellenőrző készülékek tervezése és gyártása
Lemezalkatrészek anyahegesztése

Tel.: +36 30/687-35-20 Tel.: +36 20/326-99-22

E-mail: info@iplakft.hu Web: www.celgep-gyartas.hu

